



www.urma.ch



SWISS  QUALITY

URMA Systems

URMA Tools

Reaming & Boring



Ø 0.2 - 2'400 mm	
Ø 0.2 - 40 mm	FINISHING
Ø 19.5 - 153 mm	ROUGHING
Ø 18 - 153 mm	FINISHING
Ø 49 - 297 mm	ROUGHING + FINISHING
Ø 150 - 805 mm	ROUGHING + FINISHING
Ø 500 - 2'400 mm	ROUGHING + FINISHING
Ø 20 - 51 mm	













Index

● Stock habitual
Stock standard

○ Clasificado B, consultar disponibilidad
Index B, availability on request

Indice

Table of contents

Alpha-/Beta-Modul System	Alpha-/Beta-Modul System		7
DigiTec	DigiTec		11
MicroMax	MicroMax		19
VersaMax - Tipo 14	VersaMax - Type 14		29
VersaMax - Tipo 25 / Tipo A25	VersaMax - Type 25 / Type A25		39
IntraMax	IntraMax		51
MegaMax	MegaMax		69
SuperMegaMax	SuperMegaMax		81
Sistema LBS	LBS-System		89
Componentes modulares	Modular components		97
Adaptadores modulares	Adaptor toolholders		115
Herramienta especial	Special tools		121
Estudio de mecanizado	Machining study		125
Instrucciones	Manuals		129
WinTool	WinTool		137

URMA System
Alpha-/Beta-Modul System

Ø 0.2 - 2'400 mm

Alpha-Modul-System



Conexión axial roscada

- alta estabilidad
- la simetría permite altas velocidades
- montaje sencillo
- adaptador para Beta-Modul

Axial threaded connection

- high stability
- mass symmetry allows high revolutions per minute
- simpler handling
- adaptor for Beta-Modul

Ø 0.2 - 2'400 mm

Beta-Modul-System



Sistema de bloqueo lateral

- con chaveta de anclaje
- compatible con otros sistemas
- mayor transmisión del par por mayores superficies cónicas y chaveta de anclaje
- montaje sencillo
- adaptador Alpha-Modul

With side lock system

- high flexibility
- compatible to other systems
- large surface area of conical drive key allows for higher torque transmission
- simpler handling
- adaptor for Alpha-Modul

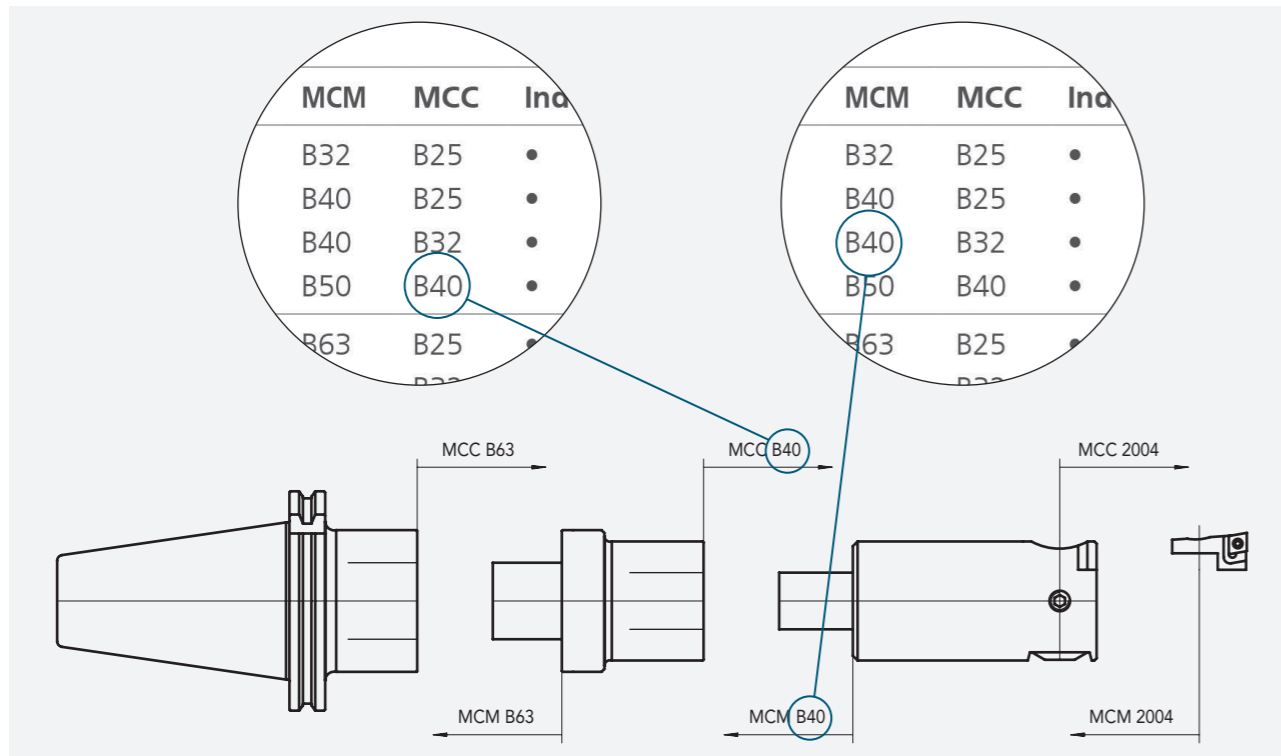

Manejo de los códigos de URMA

- MCC códigos hacia el filo de corte
- MCM códigos hacia la maquina

MCC y MCM muestran los diferentes acoplamientos para montar los elementos. Estos códigos deben corresponder el uno al otro (ver ejemplo página 8).

Handling of URMA match codes

- MCC match code towards cutting edges
- MCM match code towards machine

MCC and MCM show the different couplings to mount the tool components. These match codes have to correspond (example page 8).

URMA Systems
DigiTec

Ø 0.2 - 2'400 mm

DigiTec

El sistema de mandrinado fino a un precio justo!

The digital fine boring system at a fair price!



tecnología digital para la gama completa de la familia de mandrinado fino desde Ø 0,3 hasta 2'400m

- un solo control para toda la familia DigiTec
- sin mantenimiento y con un mínimo riesgo de error.
- la batería y el display en el control manual.
- excelente ratio precio-calidad actualización disponible en las cabezas de mandrinado fino - Versión 2011

Digital-Technology for the entire URMA fine boring head family from Ø 0.2 up to 2'400 mm

- only one control unit for the entire DigiTec family
- no maintenance and minimal risk of failure
- battery and display are located in the handheld control unit.
- excellent price-performance ratio upgrade possible on the fine boring heads - version 2011

Ø 0.2 - 2'400 mm

...ajustable en micras, incluso en la máquina - facil y preciso!

...adjustable in microns, even in the machine - easy and faultless!



más ventajas

- la más alta precisión a través de la medición directa del movimiento
- pantalla digital grande, igual a no errores de ajuste
- protege la manipulación, incluso en condiciones de poca luz (espacio en máquina, etc.)
- sencillo para cambiar métrica/pulgadas o diámetro radio
- uso híbrido - el cabezal también funciona con el nonius convencional

further advantages

- highest precision through direct measuring of the movement
- large digital display reduces setup error
- safe handling, even under poor lighting conditions (machine tool workspace, etc.)
- easy to switch metric/Inch or Diameter/Radius
- «Hybrid» usage - the boring heads also work conventionally with scale

Ø 7.3 - 25 mm

Set de herramientas

Tool-Set



Contenido

Content

Order Number	Descripción	Description	Details	Amount
05 42 30-D	Cabezal de acabado	Fine boring head DigiTec	Ø 2-40 mm	1
H06 06 07	Barra mandrinado de metal duro	Carbide boring bar	Ø 7.3-11 mm l = 24-48 mm	1
HW/C06 10 12	Barra mandrinado de metal duro	Carbide boring bar	Ø 11.8-16 mm l = 50-80 mm	1
W/C06 16 15	Barra mandrinar	Boring bar	Ø 15-20 l = 45 mm	1
07 00 06	Reductor	Reducer	Ø 6 mm	1
07 00 10	Reductor	Reducer	Ø 10 mm	1
06 16 20	Barra mandrinar	Boring bar	20-25 mm l = 60 mm	1
W/C20 02 06	Porta placa para cabezal de acabado	Fine boring insert holder		1
C00 20 01	Repuestos (tornillo amarre placa)	Spare parts (insert clamping screw)		3
C00 20 10	Repuestos (tornillo amarre placa)	Spare parts (insert clamping screw)		3
CPGT060202FXUT150	Placa de cermet	Insert cermet		10
WCGT020102FYUT150	Placa de cermet	Insert cermet		10
92 00 25-D	Control remoto para DigiTec	Display unit for DigiTec		1
DIGI 00 05	Caja vacía	Empty case		1
	Adaptador a elegir:	Adapter to choose:		
05 42 30-D 17	D10 41 16	DIN 69871-A/40	D10 41 16	DIN 69871-A/40
05 42 30-D 37	T10 41 16	MAS-BT-A/40	T10 41 16	MAS-BT-A/40
05 42 30-D 57	HSKA10 63 17	HSK63-A	HSKA10 63 17	HSK63-A

Display para cabezal de mandrinado acabado digital

Display unit for digital fine boring heads

Control remoto para DigiTec

Display unit for DigiTec

Order Number	L	B	H	kg	Index
92 00 25-D	120	80	25	0.185*	•

* incluye batería
battery included



SPARE PARTS



9V E-Block
Z92 00 25 12









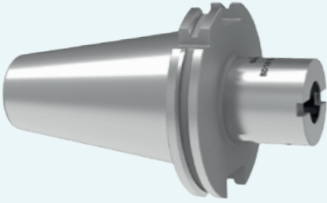

URMA Systems
MicroMax

Ø 0.2 - 40 mm

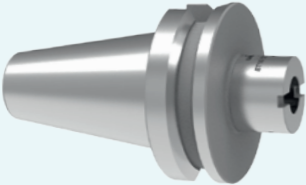
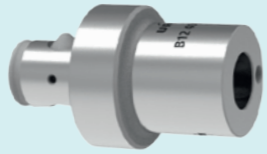
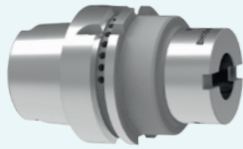
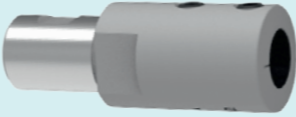
Ø 0.2 - 40 mm

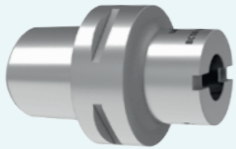
MicroMax

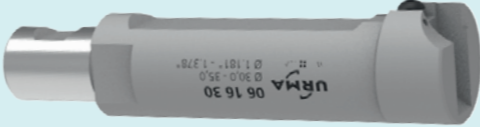
DIGITEC

page 104 - 113	page 100 - 101	from page 22	page 24	page 24
				
			page 25	page 25
				
			page 26	
				
			page 26	page 27
				

Ø 0.2 - 40 mm



DIGITEC

Cabezal acabado 1µ/ø*, con o sin características equilibrado
 Fine boring head 1 µm/ø *, with or without balancing features

Cabezal de acabado, equilibrable

Fine boring head, balanceable

Alpha	Order Number	L	D	kg	SW	MCM	MCC	Index
42	05 42 30-D	67	42	1,3	50	42	Z16	•
42	05 42 30	67	42	1,3	50	42	Z16	•

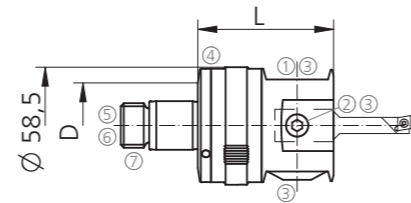

Display para cabezal de acabado digital página 17
 DigiTec display unit for digital fine boring heads page 17

Cabezal de acabado, sin equilibrar

Non balanceable fine boring head

Alpha	Order Number	L	D	kg	SW	MCM	MCC	Index
42	05 42 40-D	38	42	0,7	50	42	Z16	•
42	05 42 40	38	42	0,7	50	42	Z16	•

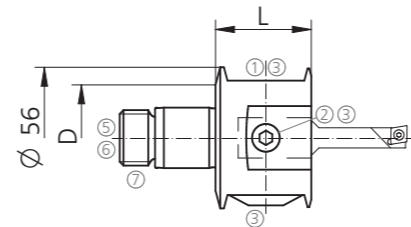

Display para cabezal de acabado digital página 17
 DigiTec display unit for digital fine boring heads page 17

SPARE PARTS

Alpha	1	2	3	4	5	6	7
42	Z00 05 01	Z00 23 01	G00 02 06	G00 02 03	G00 02 04	G00 02 07	Z00 22 42

Ø 0.2 - 40 mm



DIGITEC

Cabezal acabado 1µ/ø*, con o sin características equilibrado
 Fine boring head 1 µm/ø *, with or without balancing features

Cabezal de acabado, con equilibrado

Fine boring head, balanceable

Beta	Order Number	L	D	kg	MCM	MCC	Index
40	B05 40 30 067-D	67	42	1,3	B40	Z16	•
40	B05 40 30 067	67	42	1,3	B40	Z16	•

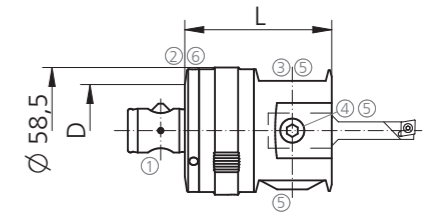

Display para cabezal de acabado digital página 17
 DigiTec display unit for digital fine boring heads page 17

* Sólo con versión DigiTec (-D) en conexión con el display (página 17) de lo contrario 10 µm/ø de ajuste
 Only with DigiTec version (-D) in connection with the display (page 17) otherwise 10 µm/ø adjustable

SPARE PARTS

Beta	1	2	3	4	5	6
40	Z00 40 21	Z00 40 23	Z00 05 01	Z00 23 01	G00 02 06	G00 02 03

Ø 0.2 - 6 mm



Barras mandrinar

Boring bars

Reductor para mini-barras de mandrinar

Reducer for mini-boring bars

Ø 0,3 - 6 mm

Order Number	L	MCM	MCC	Index
B105.0016.U1.01	39	Z16	B105	●

Ojo: Fijarse en la rotacion
Attention: Note the direction of cutting!

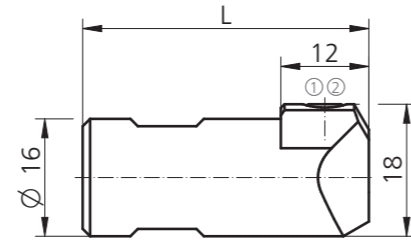

Mini-barras metal duro mandrinar

Carbide mini-boring bars

Ø 0,3 - 6 mm

Order Number	Ø-range	L	I	MCM	Index
L105.1802.0.02MG12	0.2 - 0.8	23	1,0	B105	●
L105.1802.0.03MG12	0,3 - 0,9	23	1,0	B105	●
L105.1803.0.07MG12	0,7 - 2,3	23	2,0	B105	●
R105.1805.1.1TN35	1,0 - 3,4	25	6,0	B105	●
R105.1809.1.2TN35	2,0 - 6,0	25	9	B105	●

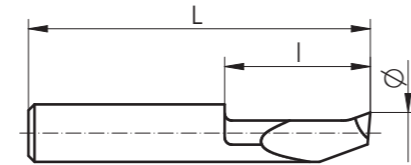

SPARE PARTS

B105..	①	②
	6.075T15	G00 20 03

Ø 5.8 - 22.5 mm



Barras mandrinar mango metal duro para mandrinar hasta 8xD

Boring bars with carbide shank for boring depths up to 8xD

Reductores

Reducers

Ø 5,8 - 22,5 mm

Order Number	L	D	d	MCM	MCC	Index
07 00 05	17	5	16	Z16	ZS5	●
07 00 06	17	6	16	Z16	ZS6	●
07 00 08	22	8	19	Z16	ZS8	●
07 00 10	25	10	22	Z16	ZS10	●
07 00 12	31	12	22	Z16	ZS12	●

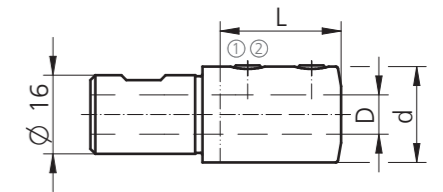

Barras mandrinar mango metal duro

Boring bars with carbide shanks

Ø 5,8 - 22,5 mm

Order Number	Ø-range	L	I	D	Inserts	MCM	MCC	Index
H06 05 06	5,8 - 10	65	20-40	5	WC.. 0201	ZS5	WC02	●
H06 06 07	7,3 - 11	70	24-48	6	WC.. 0201	ZS6	WC02	●
HW/C06 08 09	8,8 - 13	90	40-64	8	CC../CP.. 0602	ZS8	CP06	●
HW/C06 10 12	11,8 - 16	105	50-80	10	CC../CP.. 0602	ZS10	CP06	●
HW/C06 12 14	13,8 - 18	120	60-96	12	CC../CP.. 0602	ZS12	CP06	●
HW/C06 16 16	15,8 - 20	130	100	16	CC../CP.. 0602	ZS16	CP06	●
HW/C06 16 18	18,3 - 22,5	145	115	16	CC../CP.. 0602	ZS16	CP06	●

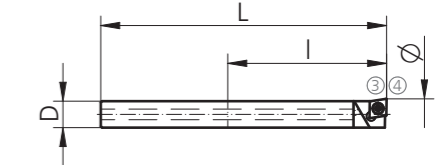

Porta herramientas combinado con porta placas ver página 27

Insert holder with combined insert pocket see page 27

SPARE PARTS

D	①	②	③	④
5-6	C00 07 01	G00 02 03	C00 20 10	G00 20 01
8-10	C00 25 03	G00 02 04	C00 20 04	G00 20 05
10-12	C00 07 02	G00 02 04	C00 20 01	G00 20 05
16			C00 20 01	G00 20 05

Ø 10 - 40 mm



Barras mandrinar con mango acero
Boring bars with steel shank

Barras mandrinar Ø 20 - 40 mm
Boring bars

Order Number	Ø-range	L	I	D	Inserts	MCM	MCC	Index
W/C06 16 10	10 - 15	38	35	8	CC../CP.. 0602..	Z16	CP06	●
W/C06 16 15	15 - 20	48	45	12,5	CC../CP.. 0602..	Z16	CP06	●
W06 16 10	10 - 15	38	35	8	CC.. 0602..	Z16	CC06	●
W06 16 15	15 - 20	48	45	12,5	CC.. 0602..	Z16	CC06	●

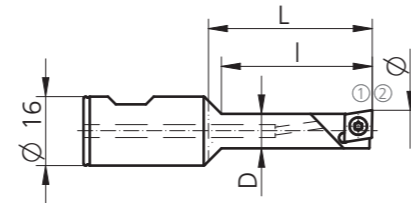

Barras mandrinar Ø 20 - 40 mm
Boring bars

Order Number	Ø-range	L	I	D	MCM	MCC	Index
06 16 20	20 - 25	60	47	17	Z16	2002	●
06 16 25	25 - 30	75	62	22	Z16	2002	●
06 16 30	30 - 35	75	62	27	Z16	2002	●
06 16 35	35 - 40	75	62	32	Z16	2002	●

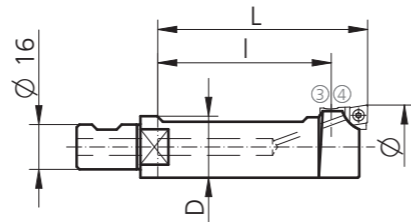

SPARE PARTS

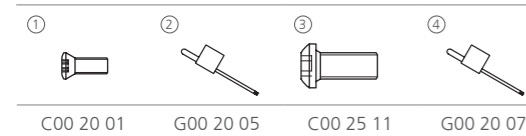

C00 20 01 G00 20 05 C00 25 11 G00 20 07

Ø 10 - 40 mm



Porta placas
Insert holders

Porta placas Ø 20 - 40 mm
Insert holders

Order Number	L	Inserts	MCM	MCC	Index
W/C20 02 06	13	CC../CP.. 0602..	2002	CP06	●
W20 02 06	13	CC.. 0602..	2002	CC06	●
WW20 02 06	13	Wiper CC.. 0602..	2002	CC06	●

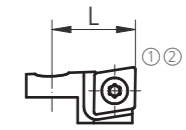

Porta placas con asiento combinado
Insert holder with combined insert pocket

Los porta placas tipo W/C... y barras de mandrinar HW/C06... estan diseñadas para placas de 7° (CCGT...) asi como 11° (CCGT...). Recomendamos utilizar las placas (afiladas) (CCG... o CPG...) en estos portas para garantizar un ajuste perfecto.

Insert holders type W/C... and boring bars HW/C06... are designed to hold inserts with 7° (CCGT...) as well as 11° (CPGT...) clearance angle. We highly recommend to use only precision (ground) inserts (CCG... or CPG...) on such holders to guarantee a perfect fit.

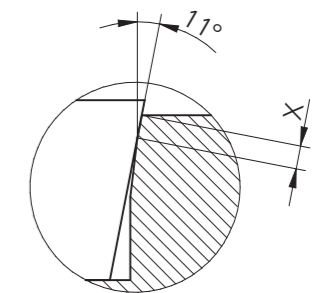
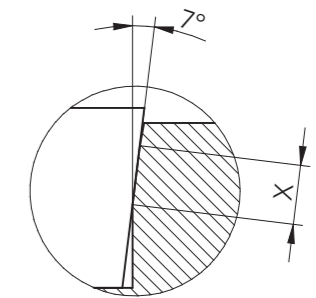

SPARE PARTS



C00 20 04 G00 20 05

URMA Systems
VersaMax - Type 14

Ø 19.5 - 153 mm

Ø 19.5 - 153 mm

VersaMax - Type 14

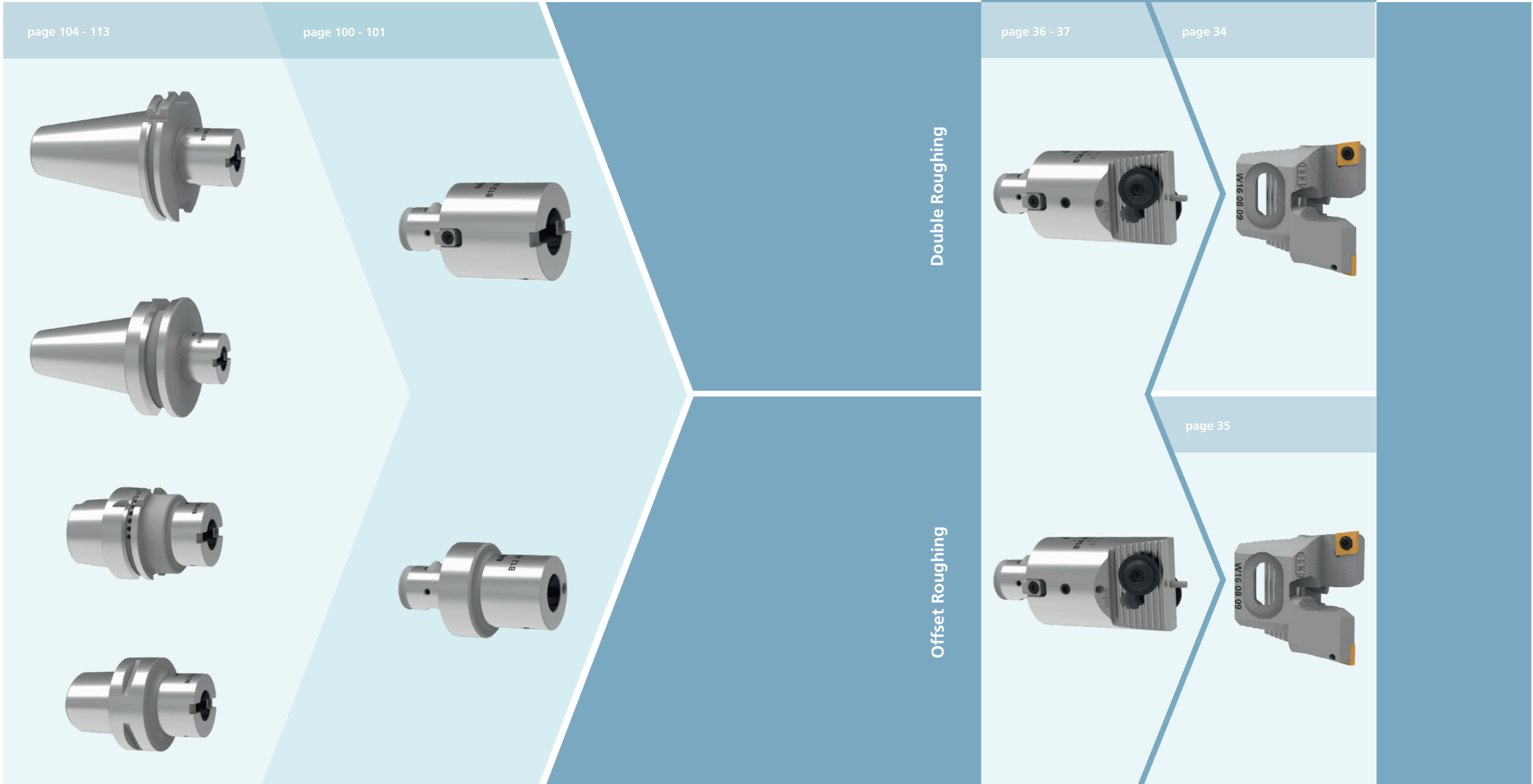

Ø 19.5 - 153 mm

Ventajas del cabezal de doble corte patentado de URMA

Advantages of the patented URMA double cutter head

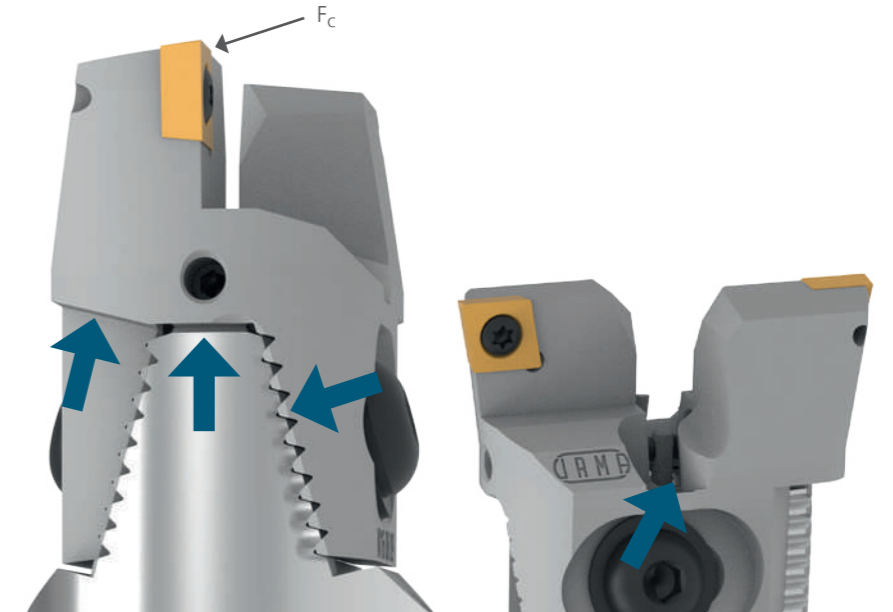

Diseño patentado para dirigir las fuerzas de corte (F_c) directamente al cuerpo y garantizar la mas alta estabilidad, versatilidad y permite:

- Desbaste de doble corte
- Desbaste desplazado
- Ajuste radial individual
- Placas estandar ISO
- Refrigeracion al eje
- Alta fiabilidad
- Manejo sencillo
- Mejor rigidez demostrable

Patented design to direct cutting forces (F_c) directly into the body and guarantee highest stability, versatility and allows:

- Double cutter roughing
- Offset roughing
- Individual radial adjustment
- ISO-Standard inserts
- Coolant through
- High reliability
- Simple handling
- Optimized stability

Desbaste desplazado Offset Roughing

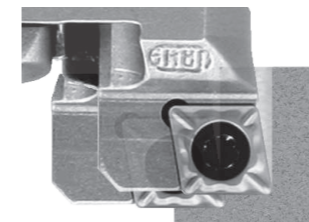

Desbaste desplazado axial y radial "Offset" para una mayor profundidad
(considerar un solo filo de corte para el calculo de avance por diente, detalles página 35)

Axial and radial offset roughing for larger cutting depth
(consider only one cutting edge for the feed rate per minute calculation, details page 35)

Ø 19.5 - 153 mm



Porta placas

Insert holders

Porta placas 90°

Insert holders 90°

Alpha	Beta	Order Number	Ø-range	kg	Inserts	MCM	MCC	Index
18,5		W16 01 06	19,5 - 25	0,1	CC.. 0602..	1418	CC06	●
18,5		W16 02 06	22,5 - 30	0,1	CC.. 0602..	1418	CC06	●
24,5	25	W16 04 06	29 - 39	0,1	CC.. 0602..	1424	CC06	●
32	32	W16 06 09	38 - 51	0,1	CC.. 09T3..	1432	CC09	●
42	40	W16 08 09	50 - 67	0,1	CC.. 09T3..	1442	CC09	●
55	63	W16 10 13	66 - 88	0,2	CC.. 1204..	1455	CC12	●
55	63	W16 10 12P	66 - 88	0,2	CN.. 1204..	1455	CN12	●
72	80	W16 12 12P	87 - 116	0,5	CN.. 1204..	1472	CN12	●
72	80	W16 12 16P	87 - 116	0,5	CN.. 1606..	1472	CN16	●
94	100	W16 14 16P	115 - 153	1,3	CN.. 1606..	1494	CN16	●

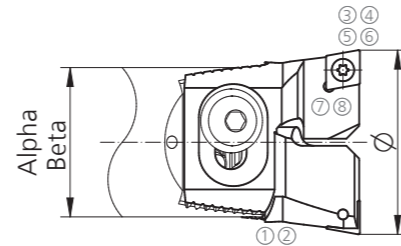

Porta placas 75°

Insert holders 75°

Alpha	Beta	Order Number	Ø-range	kg	Inserts	MCM	MCC	Index
18,5		W18 02 06	22,5 - 30	0,1	CC.. 0602..	1418	CC06	●
24,5	25	W18 04 06	29 - 39	0,1	CC.. 0602..	1424	CC06	●
32	32	W18 06 09	38 - 51	0,1	CC.. 09T3..	1432	CC09	●
42	40	W18 08 09	50 - 67	0,1	CC.. 09T3..	1442	CC09	●
55	63	W18 10 12P	66 - 88	0,2	CN.. 1204..	1455	CN12	●
72	80	W18 12 16P	87 - 116	0,5	CN.. 1606..	1472	CN16	●
94	100	W18 14 16P	115 - 153	1,3	CN.. 1606..	1494	CN16	●

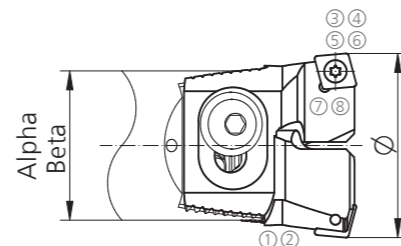

⑦⑧ No incluido en la entrega
Not included in the delivery

SPARE PARTS

Alpha	Beta	①	②	③	④	⑤	⑥	⑦	⑧
18,5		G00 02 01	C00 02 10	C00 20 01	G00 20 05				
24,5	25	G00 02 01	C00 02 11	C00 20 01	G00 20 05				
32	32	G00 02 02	C00 02 12	C00 20 02	G00 20 03				
42	40	G00 02 03	C00 02 13	C00 20 02	G00 20 03				
55	63	G00 02 03	C00 02 14	C00 20 05	G00 20 03				
55	63	G00 02 03	C00 02 14		G00 20 03	A00 12 11	Z00 12 02	A00 02 17	A00 32 07
72	80	G00 02 04	C00 02 15		G00 20 03	A00 12 11	Z00 12 02	A00 02 17	A00 32 07
72	80	G00 02 04	C00 02 15		G00 20 03	A00 12 12	Z00 16 03	A00 02 16	A00 32 08
94	100	G00 02 05	C00 02 16		G00 20 03	A00 12 12	Z00 16 03	A00 02 16	A00 32 08

Ø 22.5 - 153 mm



Porta placas para desbaste desplazado "Offset"

Insert holders for offset roughing

Placas desplazadas en diámetro y altura

Reparto óptimo de la profundidad de corte

Capacidad de doble profundidad de corte con la mitad de avance

Inserts offset in diameter and height

Equal chip load

Double cutting depth capacity with half the feed rate

Porta placas 90°

Insert holders 90°

Alpha	Beta	Order Number	Order Number	Ø-range	kg	Inserts	a _{p max}	x	MCM	MCC	Index
18,5		WV16 02 06	W16 02 06	22,5 - 30	0,1	CC.. 0602..	2-3	0,2	1418	CC06	●
24,5	25	WV16 04 06	W16 04 06	29 - 39	0,1	CC.. 0602..	2-3	0,2	1424	CC06	●
32	32	WV16 06 09	W16 06 09	38 - 51	0,1	CC.. 09T3..	3-4	0,2	1432	CC09	●
42	40	WV16 08 09	W16 08 09	50 - 67	0,2	CC.. 09T3..	3-4	0,25	1442	CC09	●
55	63	WV16 10 12P	W16 10 12P	66 - 88	0,5	CN.. 1204..	4-6	0,3	1455	CN12	●
72	80	WV16 12 12P	W16 12 12P	87 - 116	1,2	CN.. 1204..	4-6	0,3	1472	CN12	●
94	100	WV16 14 16P	W16 14 16P	115 - 153	3,0	CN.. 1606..	6-8	0,4	1494	CN16	●

Formula $a_p = \frac{D_A - D_i}{4}$

⑦⑧ No incluido en la entrega
Not included in the delivery

SPARE PARTS

Alpha	Beta	①	②	③	④	⑤	⑥	⑦	⑧
18,5		G00 02 01	C00 02 10	C00 20 01	G00 20 05				
24,5	25	G00 02 01	C00 02 11	C00 20 01	G00 20 05				
32	32	G00 02 02	C00 02 12	C00 20 02	G00 20 03				
42	40	G00 02 03	C00 02 13	C00 20 02	G00 20 03				
55	63	G00 02 03	C00 02 14		G00 20 03	A00 12 11	Z00 12 02	A00 02 17	A00 32 07
72	80	G00 02 04	C00 02 15		G00 20 03	A00 12 11	Z00 12 02	A00 02 17	A00 32 07
94	100	G00 02 05	C00 02 16		G00 20 03	A00 12 12	Z00 16 03	A00 02 16	A00 32 08

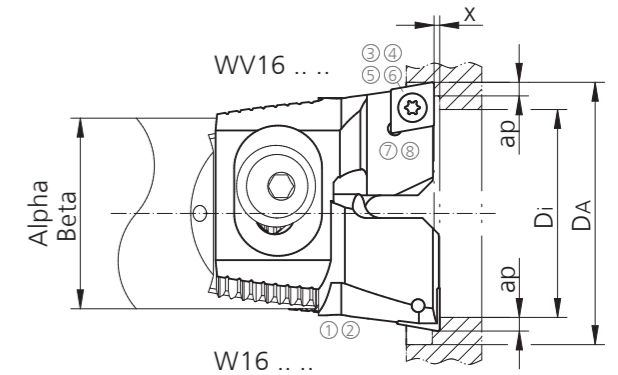

Ø 19.5 - 153 mm



Cabezales de doble corte

Double cutter heads

Cabezales de doble corte

Double cutter heads

Alpha	Order Number	Ø-range	L	D	kg	SW	MCM	MCC	Index
18,5	14 18 00	19,5 - 30	40	18,5	0,1	17	18,5	1418	●
24,5	14 24 00	29 - 39	50	24,5	0,2	22	24,5	1424	●
32	14 32 00	38 - 51	65	32	0,3	27	32	1432	●
42	14 42 00	50 - 67	90	42	0,6	36	42	1442	●
55	14 55 00	66 - 88	115	55	1,3	46	55	1455	●
72	14 72 00*	87 - 116	150	72	2,9	60	72	1472	●
94	14 94 00*	115 - 153	195	94	6,3	75	94	1494	●

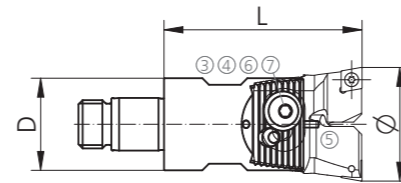

⑨ No incluido en la entrega
Not included in the delivery

* con chaveta de anclaje
supplied with a driving key

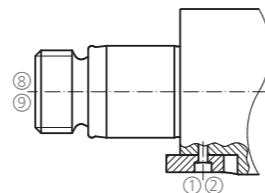

SPARE PARTS

Alpha	①	②	③	④	⑤	⑥	⑦	⑧	⑨
18,5			B00 22 01		C00 12 01	K00 02 01	G00 20 23		
24,5			B00 22 02		C00 12 01	K00 02 02	G00 20 24		
32			B00 22 03	G00 02 05	C00 12 08	K00 02 03			
42			B00 22 04	G00 02 06	C00 12 04	K00 02 04			
55			B00 22 05	G00 02 07	C00 12 05	K00 02 05			
72	Z00 00 72	C00 22 11	B00 22 06	G00 02 08	C00 12 06	K00 02 06	Z00 14 74	53 74 96	
94	Z00 00 94	C00 24 17	B00 22 07	G00 02 10	C00 12 07	K00 02 07	Z00 14 96	53 74 96	

Ø 29 - 153 mm



Cabezales de doble corte

Double cutter heads

Cabezales de doble corte

Double cutter heads

Beta	Order Number	Ø-range	L	D	kg	MCM	MCC	Index
25	B14 25 00 050	29 - 39	50	25	0,2	B25	1424	●
32	B14 32 00 065	38 - 51	65	32	0,3	B32	1432	●
40	B14 40 00 090	50 - 67	90	42	0,6	B40	1442	●
63	B14 63 00 100	66 - 88	100	63	1,5	B63	1455	●
80	B14 80 00 115	87 - 116	115	80	2,5	B80	1472	●
100	B14 100 00 145	115 - 153	145	100	4,4	B100	1494	●

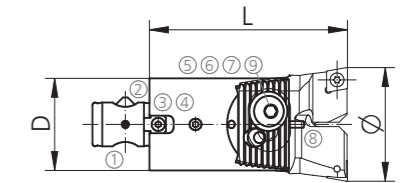

SPARE PARTS

Beta	①	②	③	④	⑤	⑥	⑦	⑧	⑨
25	Z00 25 21	Z00 25 23			B00 22 02		C00 12 01	K00 02 02	G00 20 24
32	Z00 32 21	Z00 32 23			B00 22 03	G00 02 05	C00 12 08	K00 02 03	
40	Z00 40 21	Z00 40 23	Z00 40 25	C00 22 58	B00 22 04	G00 02 06	C00 12 04	K00 02 04	
63	Z00 63 21	Z00 63 23	Z00 63 25	C00 22 05	B00 22 05	G00 02 07	C00 12 05	K00 02 05	
80	Z00 80 21	Z00 80 23	Z00 80 25	C00 22 07	B00 22 06	G00 02 08	C00 12 06	K00 02 06	
100	Z00 100 21	Z00 100 23	Z00 100 25	C00 22 71	B00 22 07	G00 02 10	C00 12 07	K00 02 07	

URMA Systems
VersaMax - Type 25 / A25

Ø 18 - 153 mm

Ø 18 - 153 mm

VersaMax - Type 25 / Type A25

DIGITEC

page 104 - 113

page 100 - 101

page 42 - 43

page 48 - 49

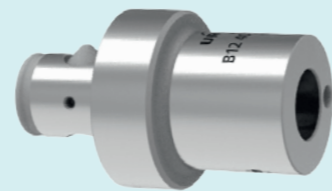
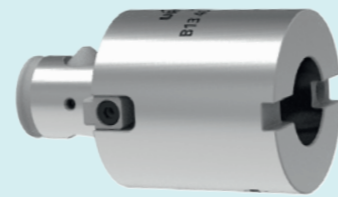
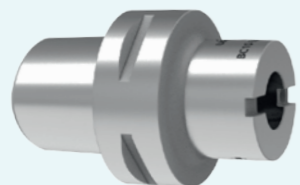
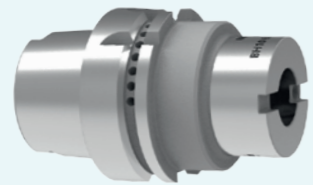
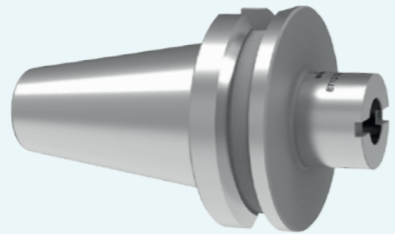
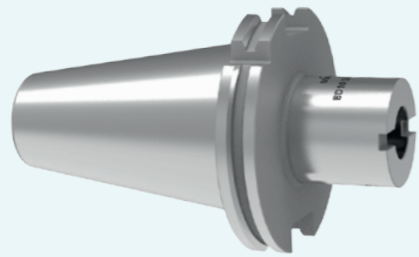

page 46 - 47

Ø 18 - 153 mm



DIGITEC

Cabezales de acabado 1 µm/Ø *
Fine boring heads 1 µm/Ø *

Cabezales de acabado
Fine boring heads

Alpha	Order Number	Ø-range	L	D	d	kg	SW	MCM	MCC	Index
24,5	25 24 30-D	29 - 39	50	26	24,5	0,2	22	24,5	2002	●
32	25 32 30-D	38 - 51	65	32	32	0,4	27	32	2004	●
42	25 42 30-D	50 - 67	90	42	42	1	36	42	2004	●
55	25 55 30-D	66 - 88	115	55	55	2,2	46	55	2006	●
72	25 72 30-D	87 - 116	75	72	72	2,5	55	72	2006	●
94	25 94 30-D	115 - 153	95	94	94	5,2	55	94	2006	●
18,5	25 16 00	18 - 22,5	65	16	18,5	0,2	17	18,5	2016	●
18,5	25 08 00	20 - 25	40	19,7	18,5	0,1	17	18,5	2002	●
18,5	25 18 00	22,5 - 30	40	20	18,5	0,1	17	18,5	2002	●
24,5	25 24 30	29 - 39	50	26	24,5	0,2	22	24,5	2002	●
32	25 32 30	38 - 51	65	32	32	0,4	27	32	2004	●
42	25 42 30	50 - 67	90	42	42	1	36	42	2004	●
55	25 55 30	66 - 88	115	55	55	2,2	46	55	2006	●
72	25 72 30	87 - 116	75	72	72	2,5	55	72	2006	●
94	25 94 30	115 - 153	95	94	94	5,2	55	94	2006	●

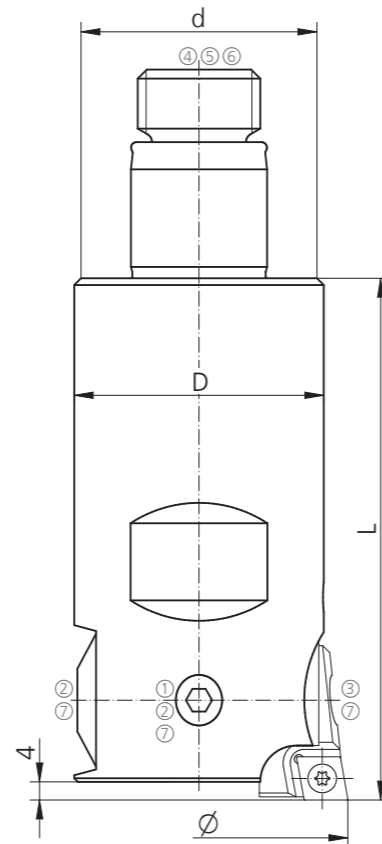

Display para cabezal de acabado digital página 17
DigiTec display unit for digital fine boring heads page 17

* Sólo con versión DigiTec (-D) en conexión con el display (página 17) de lo contrario 10 µm/Ø de ajuste
Only with DigiTec version (-D) in connection with the display (page 17) otherwise 10 µm/Ø adjustable

SPARE PARTS

Alpha	Ø-range	1	2	3	4	5	6	7
18,5	18 - 22,5	C00 25 18		C00 25 19	G00 02 04	G00 02 01	Z00 10 18	G00 20 02
18,5	20 - 30	C00 25 01		C00 25 11	G00 02 04	G00 02 01	Z00 10 18	G00 20 07
24,5		C00 25 02		C00 25 11	G00 02 05	G00 02 02	Z00 12 24	G00 20 07
32		C00 25 03	G00 02 04	C00 25 12	G00 02 06	G00 02 03	Z00 16 32	G00 20 03
42		C00 25 04	G00 02 04	C00 25 12	G00 02 07	G00 02 04	Z00 22 42	G00 20 03
55		C00 25 05	G00 02 06	C00 25 13	G00 02 05	G00 02 08	Z00 27 55	
72		C00 25 05	G00 02 06	C00 25 13	G00 02 10	G00 02 08	Z00 15 74	
94		C00 25 05	G00 02 06	C00 25 13	G00 02 10	G00 02 08	Z00 15 96	

Ø 29 - 153 mm



DIGITEC

Cabezales de acabado 1 µm/Ø *
Fine boring heads 1 µm/Ø *

Cabezales de acabado
Fine boring heads

Beta	Order Number	Ø-range	L	D	d	kg	MCM	MCC	Index
25	B25 25 30 050-D	29 - 39	50	26	25	0,2	B25	2002	●
32	B25 32 30 065-D	38 - 51	65	32	32	0,4	B32	2004	●
40	B25 40 30 090-D	50 - 67	90	42	40	1	B40	2004	●
63	B25 63 30 100-D	66 - 88	100	63	63	2,5	B63	2006	●
80	B25 80 30 115-D	87 - 116	115	80	80	4,3	B80	2006	●
100	B25 100 30 145-D	115 - 153	145	100	100	9,2	B100	2006	●
25	B25 25 30 050	29 - 39	50	26	25	0,2	B25	2002	●
32	B25 32 30 065	38 - 51	65	32	32	0,4	B32	2004	●
40	B25 40 30 090	50 - 67	90	42	40	1	B40	2004	●
63	B25 63 30 100	66 - 88	100	63	63	2,5	B63	2006	●
80	B25 80 30 115	87 - 116	115	80	80	4,3	B80	2006	●
100	B25 100 30 145	115 - 153	145	100	100	9,2	B100	2006	●

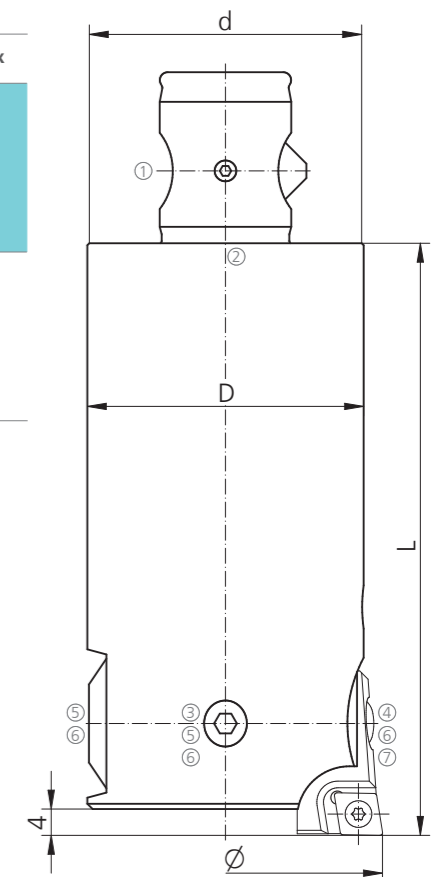

Display para cabezal de acabado digital página 17
DigiTec display unit for digital fine boring heads page 17

* Sólo con versión DigiTec (-D) en conexión con el display (página 17) de lo contrario 10 µm/Ø de ajuste
Only with DigiTec version (-D) in connection with the display (page 17) otherwise 10 µm/Ø adjustable

SPARE PARTS

Beta	1	2	3	4	5	6	7
25	Z00 25 21	Z00 25 23	C00 25 02	C00 25 11		G00 20 07	
32	Z00 32 21	Z00 32 23	C00 25 03	C00 25 12	G00 02 04	G00 20 03	
40	Z00 40 21	Z00 40 23	C00 25 04	C00 25 12	G00 02 04	G00 20 03	
63	Z00 63 21	Z00 63 23	C00 25 05	C00 25 13	G00 02 06		G00 02 05
80	Z00 80 21	Z00 80 23	C00 25 05	C00 25 13	G00 02 06		G00 02 05
100	Z00 100 21	Z00 100 23	C00 25 05	C00 25 13	G00 02 06		G00 02 05

Ventajas de los cabezales de acabado con equilibrado

Advantages of balanced fine boring heads

Las características de los cabezales de acabado con equilibrado como el A25 son unas 100 veces menos de desequilibrio residual U(gmm) comparado a los cabezales de acabado estándar y permite velocidades de corte notablemente más altas! A la vez el equilibrado es muy simple, fiable y resultados en:

- mejorar el acabado superficial
- eliminación de las vibraciones del mecanizado
- mejor tolerancia de cilindridad
- mejora de la vida de las placas

Balancable fine boring heads such as the A25 features up to 100 times less residual imbalance U (gmm) compared to standard fine boring heads and allow remarkably higher revolutions per minute! At the same time the balancing is most simple, reliable and results in:

- best surface quality
- vibration free machining
- better roundness tolerance
- improved tool life

An additional investment that pays back!

Una inversión adicional que retorna!

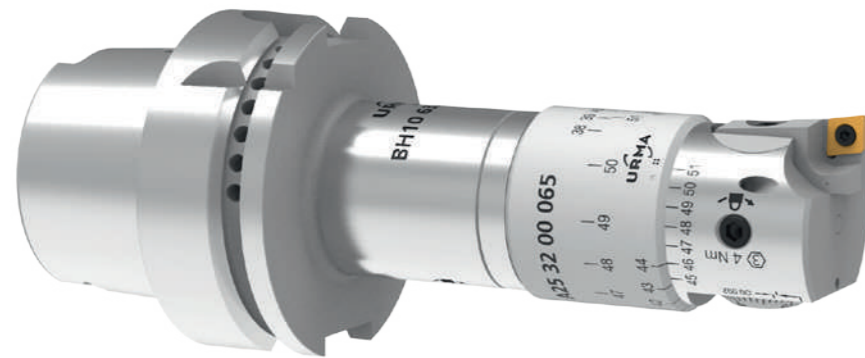

Manejo sencillo para el equilibrado
Easy to handle balancing

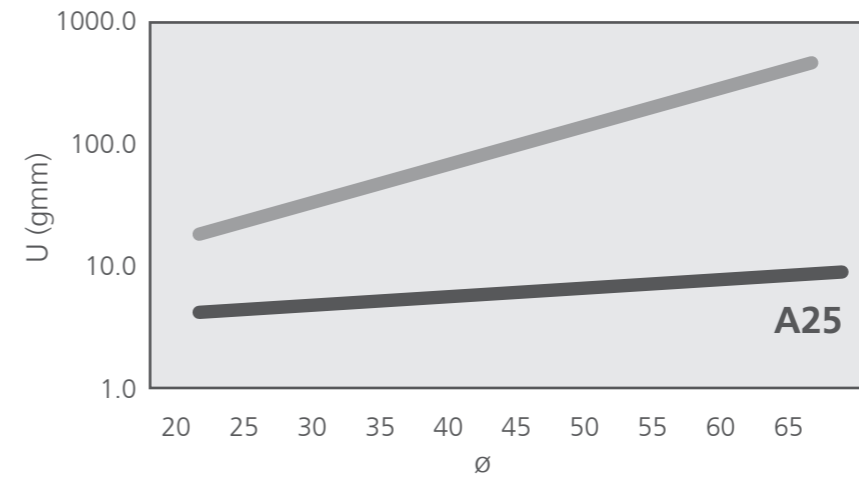
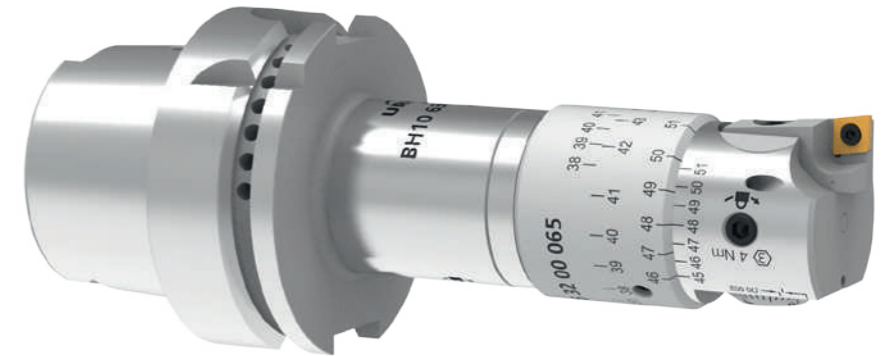

Comparación del A25 contra un cabezal de acabado convencional
Comparison A25 to conventional fine boring head

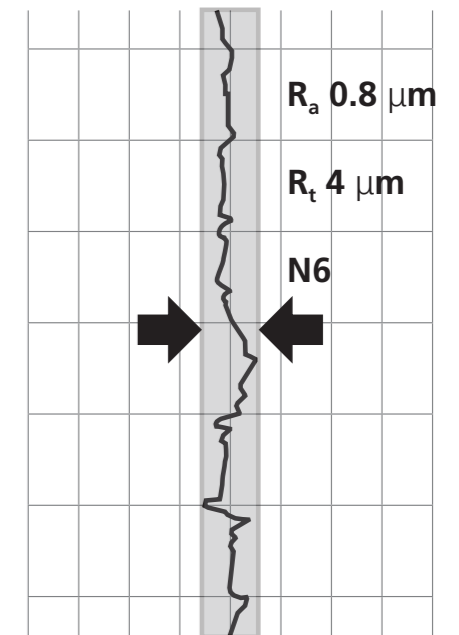

Mejor acabado superficial
Better surface quality

Ø 20 - 30 mm



Cabezales de acabado con equilibrado 2 µm/ø
Balanceable fine boring heads 2 µm/ø

Cabezales de acabado
Fine boring heads

Alpha	Order Number	Ø-range	L	D	d	kg	SW	MCM	MCC	Index
18,5	A25 08 00	20 - 25	40	19,7	18,5	0,1	17	18,5	2002	●
18,5	A25 18 00	22,5 - 30	40	21	18,5	0,1	17	18,5	2002	●

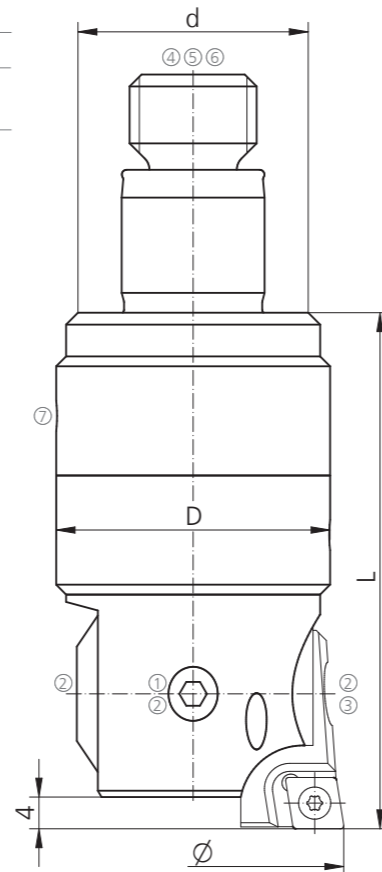

SPARE PARTS

Alpha	1	2	3	4	5	6	7
18,5	C00 25 01	G00 20 07	C00 25 11	Z00 10 18	G00 02 01	G00 02 04	G00 02 13

Ø 29 - 67 mm



Cabezales de acabado con equilibrado 2 µm/ø
Balanceable fine boring heads 2 µm/ø

Cabezales de acabado
Fine boring heads

Beta	Order Number	Ø-range	L	D	d	kg	MCM	MCC	Index
25	A25 25 00 050	29 - 39	50	27	25	0,2	B25	2002	●
32	A25 32 00 065	38 - 51	65	34,5	32	0,4	B32	2004	●
40	A25 40 00 090	50 - 67	90	45	42	1	B42	2004	●

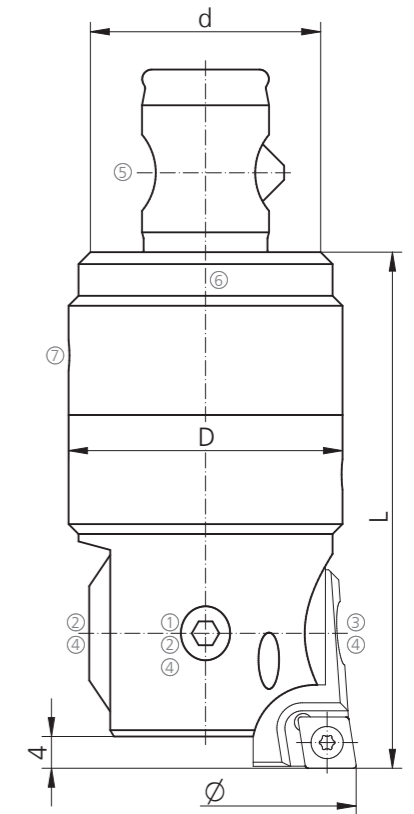

SPARE PARTS

Beta	1	2	3	4	5	6	7
25	C00 25 02		C00 25 11	G00 20 07	Z00 25 21	Z00 25 23	G00 02 01
32	C00 25 03	G00 02 04	C00 25 12	G00 20 03	Z00 32 21	Z00 32 33	G00 02 02
40	C00 25 04	G00 02 04	C00 25 12	G00 20 03	Z00 40 21	Z00 40 23	G00 02 03

Ø 18 - 153 mm



Porta placas para cabezal de acabado
Fine boring insert holders

Porta placa combinado para placas ISO con ángulo de 7° y 11°
Combination insert holders for ISO inserts with 7° and 11° clearance angle

Alpha	Beta	Order Number	Ø-range	L	Inserts	MCM	MCC	Index
18,5		W/C20 16 00 06	18 - 20,5	14	CC../CP.. 0602..	2016	CP06	●
18,5		W/C20 16 01 06	20 - 22,5	14	CC../CP.. 0602..	2016	CP06	●
18,5		W/C20 02 06	20 - 30	13	CC../CP.. 0602..	2002	CP06	●
24,5	25	W/C20 02 06	29 - 39	13	CC../CP.. 0602..	2002	CP06	●
32	32	W/C20 04 06	38 - 51	17	CC../CP.. 0602..	2004	CP06	●
42	40	W/C20 04 06	50 - 67	17	CC../CP.. 0602..	2004	CP06	●
55	63	W/C20 06 06	66 - 88	22	CC../CP.. 0602..	2006	CP06	●
72	80	W/C20 06 06	87 - 116	22	CC../CP.. 0602..	2006	CP06	●
94	100	W/C20 06 06	115 - 153	22	CC../CP.. 0602..	2006	CP06	●

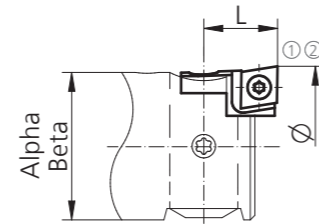

Porta herramientas combinado con porta placas ver página 27
Insert holder with combined insert pocket see page 27

Porta placa para placa ISO con ángulo de 7°
Insert holders for ISO inserts with 7° clearance angle

Alpha	Beta	Order Number	Ø-range	L	Inserts	MCM	MCC	Index
18,5		W20 02 06	20 - 30	13	CC.. 0602..	2002	CC06	●
24,5	25	W20 02 06	29 - 39	13	CC.. 0602..	2002	CC06	●
32	32	W20 04 06	38 - 51	17	CC.. 0602..	2004	CC06	●
42	40	W20 04 06	50 - 67	17	CC.. 0602..	2004	CC06	●
55	63	W20 06 09	66 - 88	22	CC.. 09T3..	2006	CC09	●
72	80	W20 06 09	87 - 116	22	CC.. 09T3..	2006	CC09	●
94	100	W20 06 09	115 - 153	22	CC.. 09T3..	2006	CC09	●

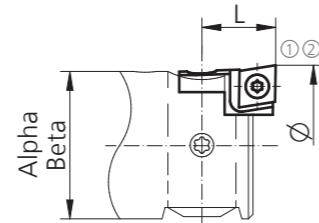

SPARE PARTS

Order Number	①	②
W/C20 02 06	C00 20 04	G00 20 05
W/C20 04 06	C00 20 01	G00 20 05
W/C20 06 06	C00 20 01	G00 20 05
W20 02 06	C00 20 04	G00 20 05
W20 04 06	C00 20 01	G00 20 05
W20 06 09	C00 20 37	G00 20 03

Ø 20 - 153 mm



Porta placas para cabezal de acabado
Fine boring insert holders

Porta placa 95° para placas Wiper de 7°
Insert holders 95° for Wiper inserts with 7° clearance angle

Alpha	Beta	Order Number	Ø-range	L	Inserts	MCM	MCC	Index
18,5		WW20 02 06	20 - 30	13	Wiper CC.. 0602..	2002	CC06	●
24,5	25	WW20 02 06	29 - 39	13	Wiper CC.. 0602..	2002	CC06	●
32	32	WW20 04 06	38 - 51	17	Wiper CC.. 0602..	2004	CC06	●
42	40	WW20 04 06	50 - 67	17	Wiper CC.. 0602..	2004	CC06	●
55	63	WW20 06 09	66 - 88	22	Wiper CC.. 09T3..	2006	CC09	●
72	80	WW20 06 09	87 - 116	22	Wiper CC.. 09T3..	2006	CC09	●
94	100	WW20 06 09	115 - 153	22	Wiper CC.. 09T3..	2006	CC09	●

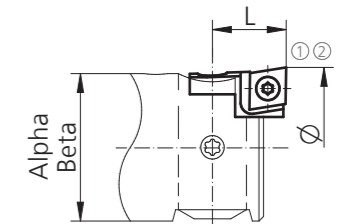

Placas Wiper
Wiper inserts

Las ventajas de las placas Wiper (doble avance y mismo acabado superficial o mejora superficial con el mismo avance) solo pueden ser utilizadas en porta placas de 95°.

The advantages of Wiper inserts (double feed rate at equal surface quality or improved surface quality at equal feed rate) can only be used with insert holders with 95° setting angle.

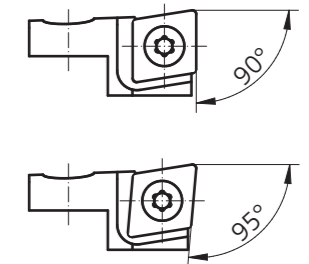

SPARE PARTS

Order Number	①	②
WW20 02 06	C00 20 04	G00 20 05
WW20 04 06	C00 20 01	G00 20 05
WW20 06 09	C00 20 37	G00 20 03

URMA Systems
IntraMax

Ø 49 - 297 mm

Ø 49 - 297 mm

IntraMax

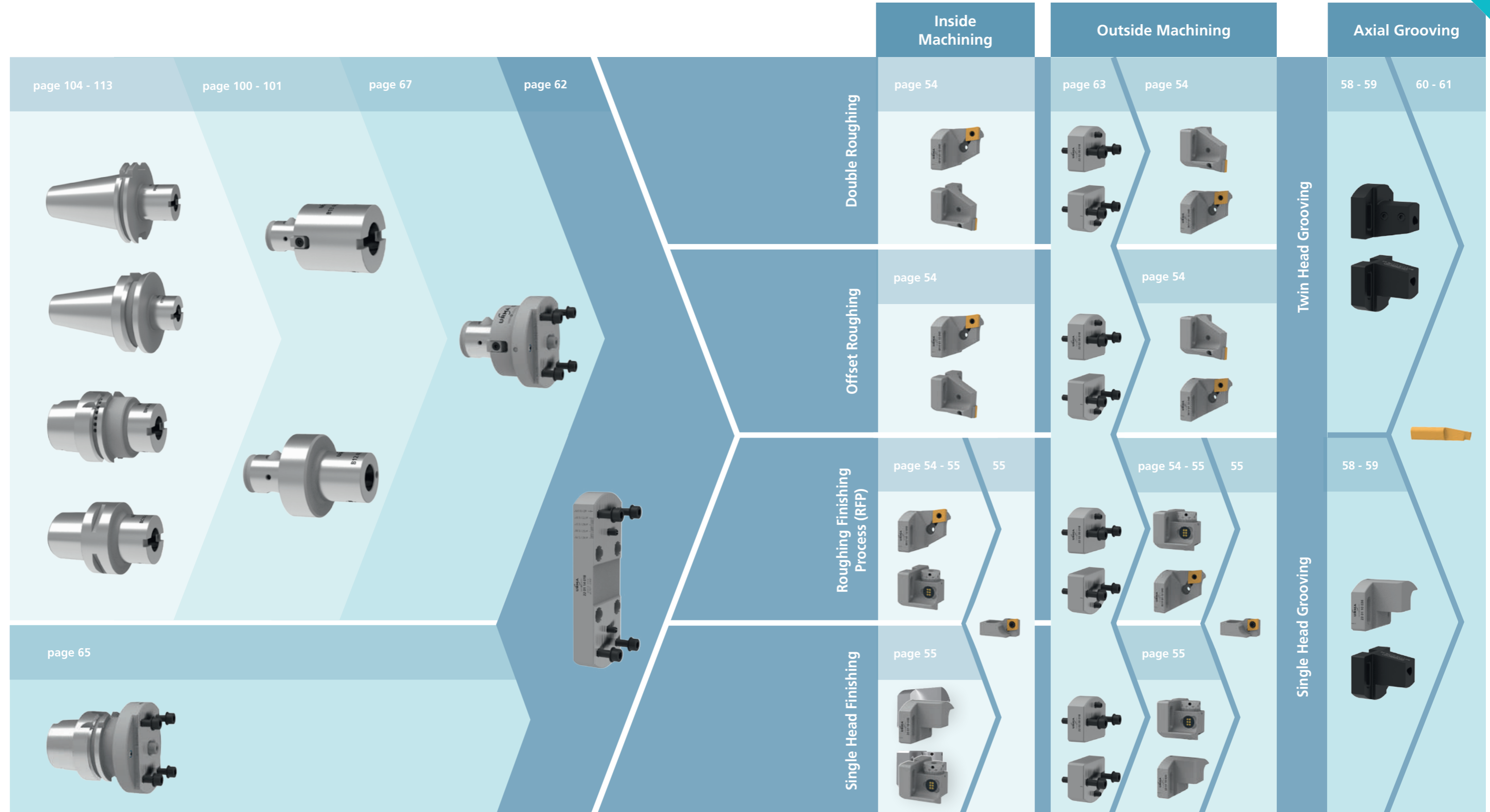

DIGITEC

Ø 49 - 297 mm

Porta placas desbaste
Insert holders roughing

Para mecanizado exterior e interior
For internal and external machining

Porta placas
Insert holders

Order Number	Ø-range	L	kg	Inserts	MCM	MCC	Index
W17 02 09 028	49 - 88	28	0,1	CC.. 09T3..	DK2203	CC09	●
W17 01 12 040	87 - 297	40	0,3	CN.. 1204..	DK2201	CN12	●

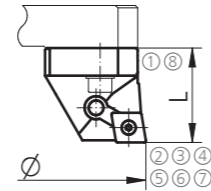

Porta placas para desbaste desplazado "Offset"
Insert holder for offset roughing

Order Number	Ø-range	L	kg	Inserts	a _p	MCM	MCC	Index
WW17 01 12 040	87 - 297	39,7	0,3	CN.. 1204..	4 - 6	DK2201	CN12	●
W17 01 12 040	87 - 297	40	0,3	CN.. 1204..	4 - 6	DK2201	CN12	●

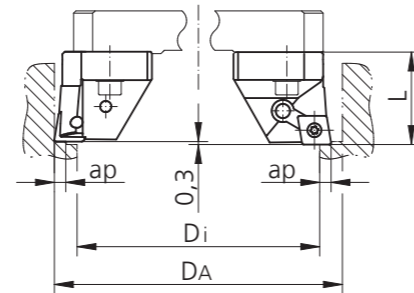

Formula $a_p = \frac{D_a - D_i}{4}$

SPARE PARTS

	①	②	③	④	⑤	⑥	⑦	⑧
W17 02..	C00 02 86		C00 20 02	G00 20 03				G00 02 01
W17 01 (WV)	C00 02 79	Z00 12 02		G00 20 03	A00 12 11	A00 02 17	A00 32 07	G00 02 02

⑥⑦ No incluido en la entrega
Not included in the delivery

Ø 49 - 297 mm

Cabezales de acabado
Fine boring heads

Para mecanizado exterior e interior
For internal and external machining

Cabezales de acabado 5 µm/Ø
Fine boring heads 5 µm/Ø

Order Number	Ø-range	L	I	kg	MCM	MCC	Index
23 02 10 028	49 - 88	28	10	0,15	DK2203	2012	●
23 01 30 040-D	87 - 297	40	18	0,4	DK2201	2010	●
23 01 30 040	87 - 297	40	18	0,4	DK2201	2010	●

Para utilizar las dos cabezas simultaneamente: A_{min} = 53
DigiTec (-D) 1 µm/Ø con display (página 17)
When using of 2 heads simultaneously: A_{min} = 53
DigiTec (-D) 1 µm/Ø with display unit (page 17)

Porta placas para cabezal de acabado
Fine boring insert holders

Order Number	Ø-range	L	Inserts	MCM	MCC	Index
WC20 12 06 000	49 - 88	18	CP..0602../CC..0602..	2012	CP06	●
WC20 10 06 000	87 - 297	22	CP..0602../CC..0602..	2010	CP06	●
W20 12 06 000	49 - 88	18	CC..0602..	2012	CC06	●
W20 10 06 000	87 - 297	22	CC..0602..	2010	CC06	●
WW20 12 06 000	49 - 88	18	Wiper CC..0602..	2012	CC06	●
WW20 10 06 000	87 - 297	22	Wiper CC..0602..	2010	CC06	●

Contrapeso
Counter weights

Order Number	Ø-range	L	kg	MCM	Index
23 02 10 024	49 - 88	28	0,1	DK2203	●
23 01 10 036	87 - 297	40	0,3	DK2201	●

SPARE PARTS

Ø-range	①	②	③	④	⑤	⑥	⑦	⑧	⑨	⑩	⑪
49 - 88	C00 02 86	C00 22 56	K00 02 44	C00 25 01	Z00 23 02		G00 20 07	G00 02 01	G00 02 03		
87 - 297	C00 02 79	C00 22 11	K00 02 01	C00 07 01	Z00 23 02			G00 02 02	G00 02 03	G00 02 04	G00 02 01
W..20							C00 20 01	G00 20 05			

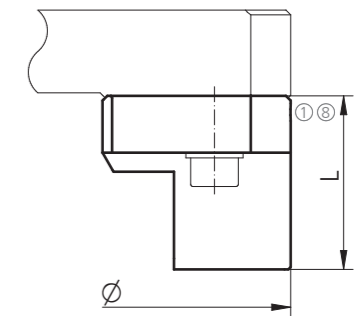
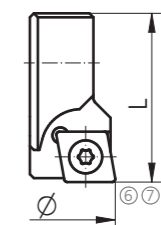
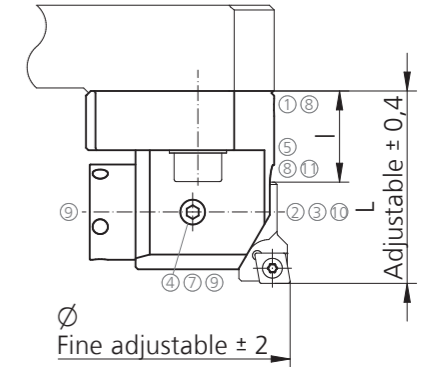

DIGITEC

Ø 49 - 297 mm	IntraMax
Ø 49 - 297 mm	MegaMax
Ø 500 - 2'400 mm	SuperMegaMax

Desbaste y acabado en un paso (RFP)

Simultaneous single-pass rough and finish (RFP)

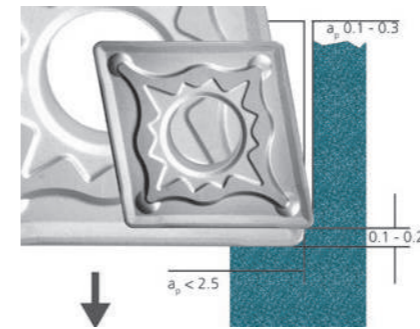

Preajuste del filo para desbaste y acabado
Presetting of roughing and finishing cutting edge



Combinacion IntraMax RFP
IntraMax RFP combination

El desbaste y acabado en un paso requiere un desplazamiento de las placas radial y axial. El tiempo de corte es reducido drásticamente.
(RFP = Roughing-Finishing-Process).

En los sistemas IntraMax y MegaMax/ SuperMegaMax RFP podemos cubrir el rango de diámetros desde 49 a 2'400 mm. La profundidad de corte recomendada en la placa de desbaste es a_p 2,5 mm para acero.

Mas ventajas:

- menor inversión en herramienta
- tiempo de mecanizado mas corto
- buena calidad superficial
- tolerancias IT7 en una sola pasada

Simultaneous single-pass roughing and finishing requires radial and axial boring head offset. Cutting time is dramatically reduced.
(RFP = Roughing-Finishing-Process)

On both systems IntraMax and MegaMax/ SuperMegaMax RFP can be applied and covers the entire diameter range from 49 to 2'400 mm. Recommended cutting depth on the roughing insert is a_p 2,5 mm for steel.

Further advantages:

- reduced tooling investment
- shorter cutting time
- high surface quality
- IT7 tolerances in one pass

Ø 5 - 45 mm

Ranurado frontal

Face grooving

Porta placa

Insert holder

Ranurado diametro exterior

Outer groove

Order Number	L	I	B	Type	Index
BKT105.U90K.01	24,5	17,5	28,5	R105	•

A partir de Ø D_{amin} = pueden ser utilizados simultaneamente dos placas (ver página 60 y 61). Para diámetro mas pequeño, solo puede ser utilizados juntos una placas mas el contrapeso.

From Ø D_{amin} = 2x (6 mm + f_{insert}) two insert holders can be used simultaneously (f see pages 60 and 61). For smaller D_{amin}, only one insert holder plus counter weight can be used together.

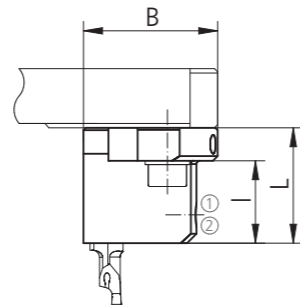

Extensores de diámetro

Diameter extender

Order Number	Ø-range	Page	Insert holder	Index
1)	5 - 18	65 - 66		•
22 03 06 012	18 - 31	62	BKT105.U90K.01	•
22 03 07 012	31 - 45	62		•

1) Directamente con el adaptador directo o intermedio (página 65 - 67)

Direct via basic holder or intermediate adaptor (pages 65 - 67)

Contrapeso

Counter weight

Order Number	L	I	B	Index
020.U00K.2040	24,5	17,5	22	•

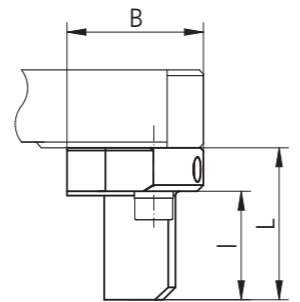

SPARE PARTS



BKT105. ... 6.075T15 G00 20 035

Ø 31 - 242 mm

Porta placa

Insert holder

Ranurado diametro exterior

Outer groove

Order Number	L	I	B	Type	Index
BKT105.U90G.01 1)	36,4	24,4	39,5	R105	•
BKT110.U17G.02 2)	41	26	39,5	RA110	•

1) A partir de Ø D_{amin} = pueden ser utilizadas simultaneamente dos placas (ver página 60 y 61). Para diámetro mas pequeño, solo puede ser utilizada una placa mas el contrapeso.

From Ø D_{amin} = 2x (6 mm + f_{insert}) two insert holders can be used simultaneously (f see pages 60 and 61). For smaller D_{amin}, only one insert holder plus counter weight can be used together.

2) A partir de Ø D_{amin} = pueden ser utilizadas simultaneamente dos placas (ver página 61). Para diámetro mas pequeño, solo puede ser utilizados juntos un porta placa mas el contrapeso.

From Ø D_{amin} = 2x (13,5 mm + f_{insert}) two insert holders can be used simultaneously (f see page 61). For smaller D_{amin}, only one insert holder plus counter weight can be used together.

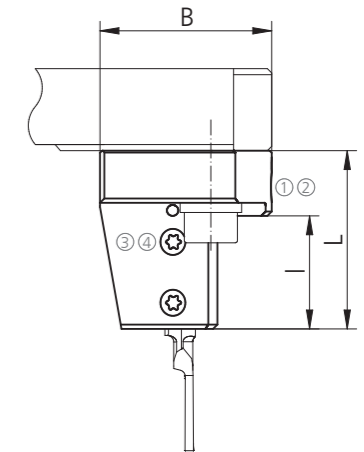

Extensores de diámetro

Diameter extender

Order Number	Ø-range	Page	Insert holder	Index
1)	31 - 61	65 - 66		•
22 01 11 018	61 - 91	62		•
22 01 14 018	91 - 122	62	BKT105.U90G.01	•
22 01 17 018	122 - 152	62	BKT110.U17G.02	•
22 01 20 023	152 - 182	62		•
22 01 23 023	182 - 212	62		•
22 01 26 028	212 - 242	62		•

1) Directamente con el adaptador directo o intermedio (página 65 - 67)

Direct via basic holder or intermediate adaptor (pages 65 - 67)

Contrapeso

Counter weight

Order Number	Ø-range	L	kg	MCM	Index
23 01 10 036	31 - 242	40	0,3	DK2201	•

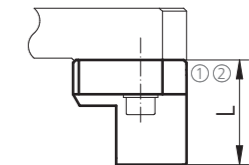

SPARE PARTS

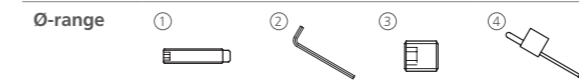

31 - 242 C00 02 79 G00 02 02 6.075T15 G00 20 030

Ranurado frontal (sistema HORN-URMA)

Face grooving (system HORN-URMA)

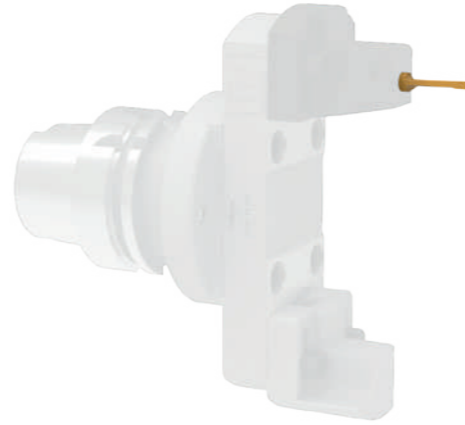

Placas tipo 105...8

Inserts type 105...8

Order Number	W ^{+0.05}	f	r	L	l	t _{max}	D _{min}	Type	Calidad metal duro		Index
									Carbide grades	MG12	
R105.0510.1.8	1,0	2,0	0,05	25	10	2,0	5,0	BKT105...	●	●	●
R105.0515.1.8	1,5	2,0	0,05	25	10	3,0	5,0	BKT105...	●	●	●
R105.0520.1.8	2,0	2,0	0,05	25	10	5,0	5,0	BKT105...	●	●	●
R105.0510.2.8	1,0	2,0	0,05	35	15	2,0	5,0	BKT105...	●	●	●
R105.0515.2.8	1,5	2,0	0,05	35	15	3,0	5,0	BKT105...	●	●	●
R105.0520.2.8	2,0	2,0	0,05	35	15	5,0	5,0	BKT105...	●	●	●
R105.0610.1.8	1,0	2,0	0,05	25	10	2,0	6,0	BKT105...	●	●	●
R105.0615.1.8	1,5	2,0	0,05	25	10	3,0	6,0	BKT105...	●	●	●
R105.0620.1.8	2,0	2,0	0,05	25	10	5,0	6,0	BKT105...	●	●	●
R105.0610.2.8	1,0	2,0	0,05	35	15	2,0	6,0	BKT105...	●	●	●
R105.0615.2.8	1,5	2,0	0,05	35	15	3,0	6,0	BKT105...	●	●	●
R105.0620.2.8	2,0	2,0	0,05	35	15	5,0	6,0	BKT105...	●	●	●
R105.0810.1.8	1,0	2,0	0,15	25	10	2,0	8,0	BKT105...	●	●	●
R105.0815.1.8	1,5	2,0	0,15	25	10	3,0	8,0	BKT105...	●	●	●
R105.0820.1.8	2,0	2,0	0,15	25	10	4,0	8,0	BKT105...	●	●	●
R105.0825.1.8	2,5	2,0	0,15	25	10	5,0	8,0	BKT105...	●	●	●
R105.0830.1.8	3,0	2,0	0,15	25	10	6,0	8,0	BKT105...	●	●	●
R105.0810.2.8	1,0	2,0	0,15	35	15	2,0	8,0	BKT105...	●	●	●
R105.0815.2.8	1,5	2,0	0,15	35	15	3,0	8,0	BKT105...	●	●	●
R105.0820.2.8	2,0	2,0	0,15	35	15	4,0	8,0	BKT105...	●	●	●
R105.0825.2.8	2,5	2,0	0,15	35	15	5,0	8,0	BKT105...	●	●	●
R105.0830.2.8	3,0	2,0	0,15	35	15	6,0	8,0	BKT105...	●	●	●

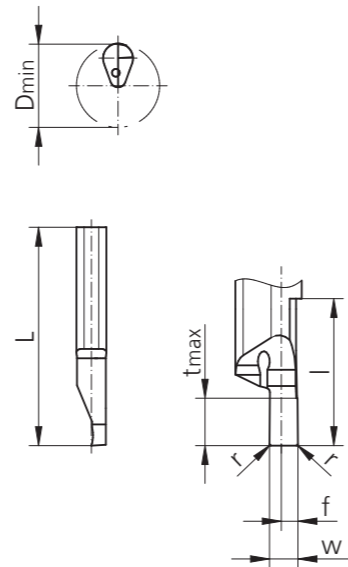

MG12

Metal duro no recubierto para velocidades bajas en acero, fundicion y metales no ferrosos

TI25

Metal duro recubierto de TiCN para velocidades medias en acero y metales no ferrosos

Más medidas y perfiles de placa bajo demanda

MG12

Uncoated carbide for low cutting speed in steel, cast iron and non-ferrous metals

TI25

TiCN coated carbide for medium cutting speed in steel and non-ferrous metals

Further dimension and insert profiles on demand

Placas tipo 105...9

Inserts type 105...9

Order Number	W ^{+0.05}	f	r	L	l	t _{max}	D _{min}	Type	Calidad metal duro		Index
									Carbide grades	TI25	
R105.0810.1.9	1,0	0,4	0,15	25	10	2,0	8,0	BKT105...	●	●	●
R105.0815.1.9	1,5	0,4	0,15	25	10	3,0	8,0	BKT105...	●	●	●
R105.0820.1.9	2,0	0,4	0,15	25	10	4,0	8,0	BKT105...	●	●	●
R105.0825.1.9	2,5	0,4	0,15	25	10	5,0	8,0	BKT105...	●	●	●
R105.0830.1.9	3,0	0,4	0,15	25	10	6,0	8,0	BKT105...	●	●	●

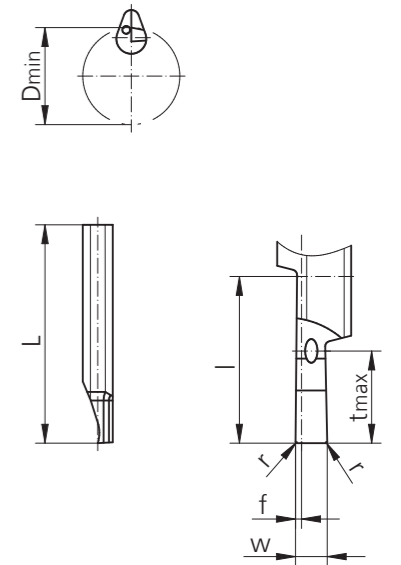

Placas tipo A110

Inserts type A110

Order Number	W ^{+0.05}	f	r	L	t _{max}	D _{min}	Type	Calidad metal duro		Index
								Carbide grades	TI25	
RA110.2030.3.0	3,0	1,5	0,2	50	20	20 - 50*	BKT110...	●	●	●
RA110.2030.5.0	3,0	1,5	0,2	60	30	20 - 50*	BKT110...	●	●	●
RA110.5030.3.0	3,0	1,5	0,2	50	20	>50	BKT110...	●	●	●
RA110.5030.5.0	3,0	1,5	0,2	60	30	>50	BKT110...	●	●	●

* El ranurado frontal con toda la profundidad disponible solo es posible entre D_a = 20 - 50 mm

Face grooving with full width to the full depth only possible between D_a = 20 - 50 mm

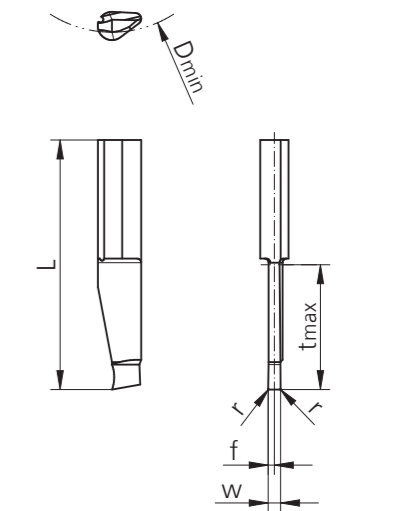

Ø 49 - 297 mm

Extensores de diámetro
Diameter extenders



Extensores de diámetro **Ø 49 - 88 mm**
Diameter extenders

Order Number	Ø-range	L	I	D	kg	MCM	MCC	Index
1)	49 - 62							●
22 03 06 012	62 - 75	12	40	59	0,2	Z2203	DK2203	●
22 03 07 012	75 - 88	12	40	72	0,3	Z2203	DK2203	●

- 1) **Directamente con el adaptador directo o intermedio (página 65 - 67)**
Direct via basic holder or intermediate adaptor (pages 65 - 67)

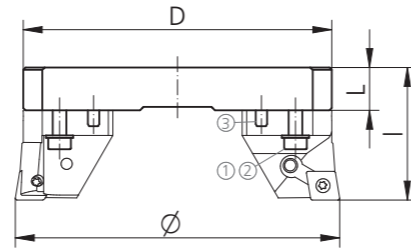

Extensores de diámetro **Ø 87 - 297 mm**
Diameter extenders

Order Number	Ø-range	L	I	D	kg	MCM	MCC	Index
1)	87 - 117						DK2201	●
22 01 11 018	117 - 147	18	58	110	0,8	Z2201	DK2201	●
22 01 14 018	147 - 177	18	58	140	1	Z2201	DK2201	●
22 01 17 018	177 - 207	18	58	170	1,2	Z2201	DK2201	●
22 01 20 023	207 - 237	23	63	200	1,6	Z2201	DK2201	●
22 01 23 023	237 - 267	23	63	230	1,9	Z2201	DK2201	●
22 01 26 028	267 - 297	28	63	260	2,6	Z2201	DK2201	●

- 1) **Directamente con el adaptador directo o intermedio (página 65 - 67)**
Direct via basic holder or intermediate adaptor (pages 65 - 67)

SPARE PARTS

Ø-range	①	②	③
49 - 88	C00 22 05	K00 02 01	C00 12 08
87 - 297	C00 22 02	K00 02 20	C00 12 61

Ø 9 - 249 mm

Adaptadores intermedios para mecanizado exterior
Intermediate adaptors for external machining



Adaptadores intermedios **Ø 9 - 35 mm**
Intermediate adaptors

Order Number	Ø-range	D	dz	ds	L	lz	lk	kg	Diameter extender	MCM	MCC	Index
22 04 00 012	9 - 22	59	74	Ø + 56 mm	28	12	12	0,1	22 03 06 012	DK2203	DK2203	●
22 04 00 012	22 - 35	72	87	Ø + 56 mm	28	12	12	0,1	22 03 07 012	DK2203	DK2203	●

Adaptadores intermedios **Ø 9 - 249 mm**
Intermediate adaptors

Order Number	Ø-range	D	dz	ds	L	lz	lk	kg	Diameter extender	MCM	MCC	Index
22 02 00 018	9 - 39	110	125	Ø + 100 mm	40	18	18	0,25	22 01 11 018	DK2201	DK2201	●
22 02 00 018	39 - 69	140	155	Ø + 100 mm	40	18	18	0,25	22 01 14 018	DK2201	DK2201	●
22 02 00 018	69 - 99	170	185	Ø + 100 mm	40	18	18	0,25	22 01 17 018	DK2201	DK2201	●
22 02 00 018	99 - 129	200	215	Ø + 100 mm	40	18	23	0,25	22 01 20 023	DK2201	DK2201	●
22 02 00 018	129 - 159	230	245	Ø + 100 mm	40	18	23	0,25	22 01 23 023	DK2201	DK2201	●
22 02 00 018	159 - 189	260	275	Ø + 100 mm	40	18	28	0,25	22 01 26 028	DK2201	DK2201	●
22 02 00 018	189 - 219	290	305	Ø + 100 mm	40	18	28	0,25	22 01 29 028	DK2201	DK2201	●
22 02 00 018	219 - 249	320	335	Ø + 100 mm	40	18	28	0,25	22 01 32 028	DK2201	DK2201	●

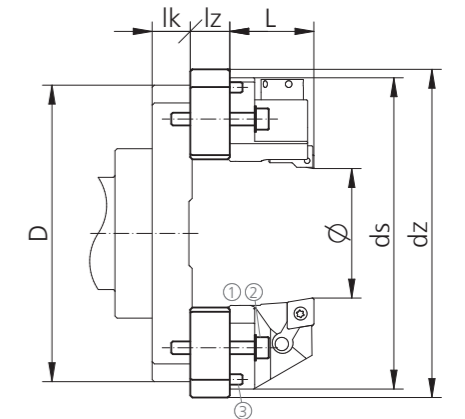
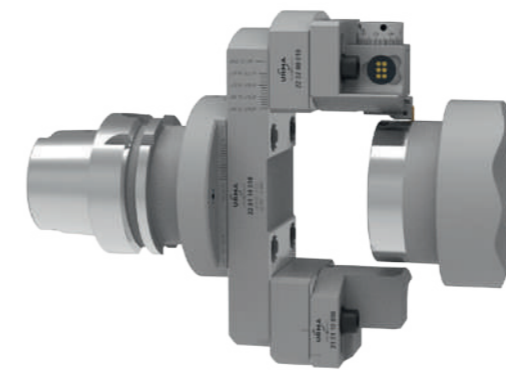

SPARE PARTS

Ø-range	①	②	③
9 - 35	C00 22 05	K00 02 01	C00 12 08
9 - 249	C00 22 74	K00 02 20	C00 12 61

Ø 49 - 297 mm

Conos/Adaptadores directos
Direct adaptors



Conos/Adaptadores directos
Direct adaptors

Order Number	□	Ø-range	D	L	kg	MCC	Index
D11 41 03 052	SK40 / A	49 - 88	46	52	1,2	Z2203	●
H11 43 03 052	SK40 / B	49 - 88	46	52	1,2	Z2203	●
T11 41 03 052	MAS-BT40	49 - 88	46	52	1,3	Z2203	●
HSKA11 63 03	HSKA-63	49 - 88	46	60	1,3	Z2203	●
D11 41 01 054	SK40 / A	87 - 297	80	54	1,4	Z2201	●
H11 43 01 054	SK40 / B	87 - 297	80	54	1,4	Z2201	●
T11 41 01 054	MAS-BT40	87 - 297	80	54	1,5	Z2201	●
HSKA11 63 01	HSKA-63	87 - 297	80	60	1,4	Z2201	●

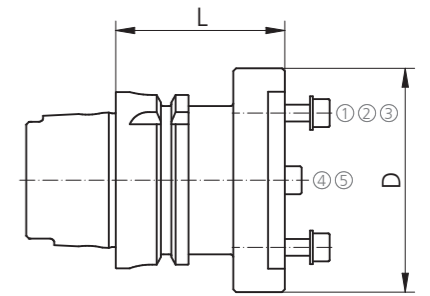

SPARE PARTS

Ø-range	①	②	③	④	⑤
49 - 88	C00 22 05	K00 02 01	G00 02 04	Z00 21 20	C00 12 08
87 - 207	C00 22 02	K00 02 20	G00 02 06	Z00 21 20	C00 12 08

Ø 49 - 297 mm

Adaptadores intermedios
Intermediate adaptors



Adaptadores intermedios
Intermediate adaptors

Alpha	Order Number	Ø-range	L	D	d	kg	MCM	MCC	Index
42	21 42 46 036	49 - 88	36	46	42	0,5	42	Z2203	●
55	21 55 80 042	87 - 297	42	80	55	0,8	55	Z2201	●

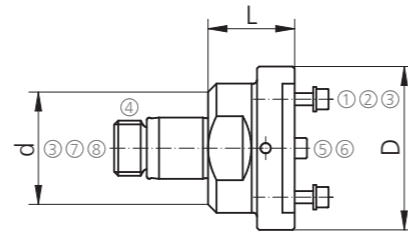

SPARE PARTS

Ø-range	①	②	③	④	⑤	⑥	⑦	⑧
49 - 88	C00 22 05	K00 02 01	G00 02 04	Z00 22 42		C00 12 08	G00 02 07	
87 - 297	C00 22 02	K00 02 20	G00 02 06	Z00 27 55	Z00 21 20		G00 02 08	G00 02 05

Ø 49 - 297 mm

Adaptadores intermedios
Intermediate adaptors



Adaptadores intermedios
Intermediate adaptors

Beta	Order Number	Ø-range	L	D	d	kg	MCM	MCC	Index
40	B21 40 46 036	49 - 88	36	46	42	0,5	B40	Z2203	●
63	B21 63 80 042	87 - 297	42	80	63	0,8	B63	Z2201	●

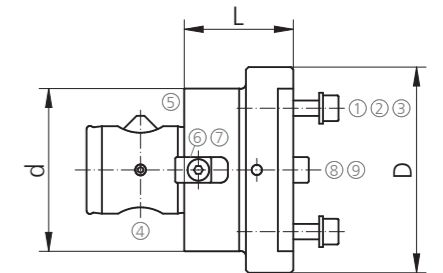

SPARE PARTS

Ø-range	①	②	③	④	⑤	⑥	⑦	⑧	⑨
49 - 88	C00 22 05	K00 02 01	G00 02 04	Z00 40 21	Z00 40 23	Z00 40 25	C00 22 58		C00 12 08
87 - 297	C00 22 02	K00 02 20	G00 02 06	Z00 63 21	Z00 63 23	Z00 63 25	C00 22 05	Z00 21 20	

URMA Systems
MegaMax

Ø 150 - 805 mm

Ø 150 - 805 mm

MegaMax

DIGITEC

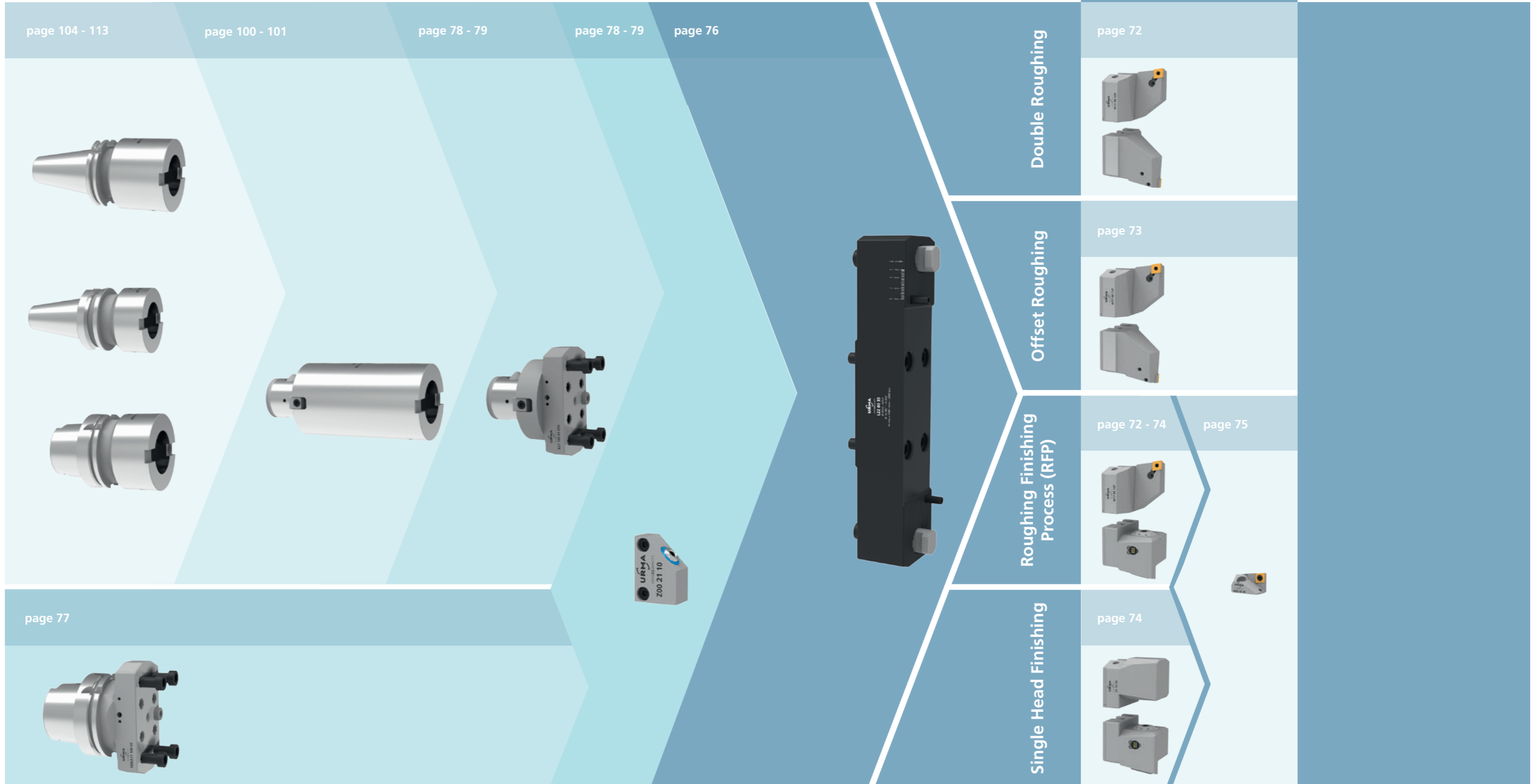

Ø 150 - 805 mm	MegaMax
Ø 500 - 2'400 mm	SuperMegaMax



Porta placas desbaste

Insert holders

Porta placas 90°

Insert holders 90°

Order Number	Ø-range	L	kg	Inserts	MCM	MCC	Index
W17 00 12P	150 - 2400	75	1,5	CN.. 1204..	K00	CN12	●
W17 00 16P	150 - 2400	75	1,5	CN.. 1606..	K00	CN16	●

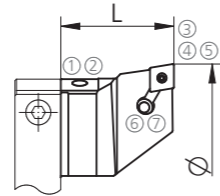

Porta placas de 90° para placas de ceramica

Insert holders 90° for ceramic inserts

Order Number	Ø-range	L	kg	Inserts	MCM	MCC	Index
K17 00 16	150 - 2400	75	1,5	CN.. 1607..	K00	CN1607	●

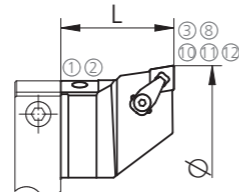

Porta placas 75°

Insert holders 75°

Order Number	Ø-range	L	kg	Inserts	MCM	MCC	Index
W19 00 16P	150 - 2400	75	1,5	CN.. 1606..	K00	CN16	●

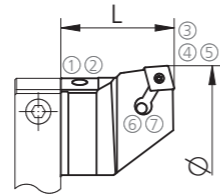

Porta placas de 75° para placas de ceramica

Insert holders 75° for ceramic inserts

Order Number	Ø-range	L	kg	Inserts	MCM	MCC	Index
K19 00 15	150 - 2400	75	1,5	SN.. 1507..	K00	SN15	●

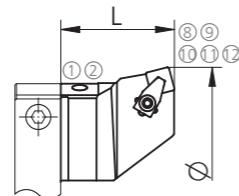

⑥⑦ No incluido en la entrega

Not included in the delivery

SPARE PARTS

①	②	③	④	⑤	⑥	⑦	⑧	⑨	⑩	⑪	⑫	
CN.. 1204..	C00 02 17	G00 02 06	A00 12 11	Z00 12 02	G00 20 03	A00 02 17	A00 32 07				G00 02 04	
CN.. 1606..	C00 02 17	G00 02 06	A00 12 12	Z00 16 03	G00 20 03	A00 02 16	A00 32 08					
CN.. 1607..	C00 02 17	G00 02 06	A00 12 18					G00 02 05	A00 02 15	A00 42 05	G00 02 04	
SN.. 1507..	C00 02 17	G00 02 06						G00 02 05	A00 12 06	A00 02 14	A00 42 05	G00 02 04

Ø 150 - 805 mm	MegaMax
Ø 500 - 2'400 mm	SuperMegaMax



Porta placas para desbaste desplazado "Offset"

Insert holders for offset roughing

Placas desplazadas en diámetro y altura

Misma profundidad de corte por placa

Capacidad de doblar la profundidad de corte

Inserts offset in diameter and height

Equal chip load

Double cutting depth capacity

Porta placas 90°

Insert holders 90°

Order Number	Ø-range	L	kg	Inserts	a _p	MCM	MCC	Index
W17 00 12P	150 - 2400	75,0	1,5	CN.. 1204..	6	K00	CN12	●
WV17 00 12P	150 - 2400	74,5	1,5	CN.. 1204..	6	K00	CN12	●
W17 00 16P	150 - 2400	75,0	1,5	CN.. 1606..	8	K00	CN16	●
WV17 00 16P	150 - 2400	74,5	1,5	CN.. 1606..	8	K00	CN16	●
K17 00 16*	150 - 2400	75,0	1,5	CNMX 1607.. T..	8	K00	CN1607	●
KV17 00 16*	150 - 2400	74,5	1,5	CNMX 1607.. T..	8	K00	CN1607	●

* para placas de ceramica con tipo de amarre Ceramtec notch
for ceramic inserts with Ceramtec notch type clamping

$$\text{Formula } a_p = \frac{D_A - D_i}{4}$$

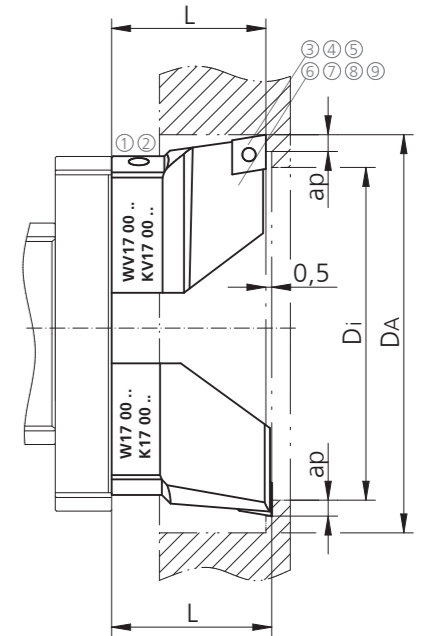

⑥⑦ No incluido en la entrega

Not included in the delivery

SPARE PARTS

①	②	③	④	⑤	⑥	⑦	⑧	⑨
CN.. 1204..	C00 02 17	G00 02 06	A00 12 11	Z00 12 02	G00 20 03	A00 02 17	A00 32 07	
CN.. 1606..	C00 02 17	G00 02 06	A00 12 12	Z00 16 03	G00 20 03	A00 02 16	A00 32 08	
CN.. 1607..	C00 02 17	G00 02 06	A00 12 18					A00 42 05
								A00 02 15

Ø 150 - 805 mm	MegaMax
Ø 500 - 2'400 mm	SuperMegaMax

Cabezales de acabado
Fine boring head

Cabezales de acabado 1 µm/ø *
Fine boring head 1 µm/ø *

Order Number	Ø-range	L	I	kg	MCM	MCC	Index
23 00 30-D	150 - 2400	77	42	2,3	K00	DK2200	●
23 00 30	150 - 2400	77	42	2,3	K00	DK2200	●

Display para cabezal de acabado digital página 17
DigiTec display unit for digital fine boring heads page 17

* Sólo con versión DigiTec (-D) en conexión con el display (página 17) de lo contrario 10 µm/ø de ajuste
Only with DigiTec version (-D) in connection with the display (page 17) otherwise 10 µm/ø adjustable

Contrapeso
Counter weight

Order Number	Ø-range	L	kg	MCM	Index
23 10 20	150 - 2400	64	2,3	K00	●

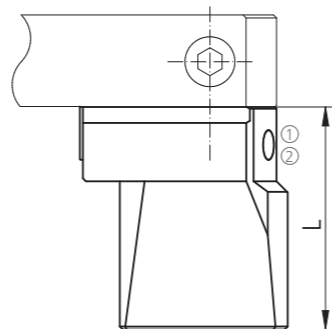
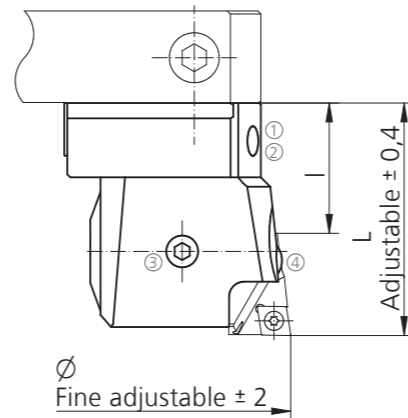

SPARE PARTS

①	②	③	④
C00 02 17	G00 02 06	Z00 23 01	C00 23 01

Ø 150 - 805 mm	MegaMax
Ø 500 - 2'400 mm	SuperMegaMax

Porta placas para cabezales de acabado
Fine boring insert holders

Porta placas 90°
Insert holders 90°

Order Number	Ø-range	L	Inserts	æ	MCM	MCC	Index
W/C20 00 06	150 - 2400	34	CP../CC.. 0602..	90	DK2200	CP06	●
W20 00 09	150 - 2400	34	CC.. 09T3..	90	DK2200	CC09	●
WW20 00 09	150 - 2400	34	WIPER CC.. 09T3	95	DK2200	CC09	●

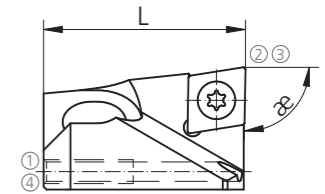

RFP - Dos operaciones en una - desbaste y acabado
For simultaneous roughing and finishing (RFP)

Porta placa 90° RFP
RFP Insert holders 90°

Order Number	Ø-range	L	Inserts	æ	MCM	MCC	Index
W20 00 09RFP	150 - 2400	31	CC.. 09T3..	90	DK2200	CC09	●
WW20 00 09RFP	150 - 2400	31	WIPER CC.. 09T3	95	DK2200	CC09	●

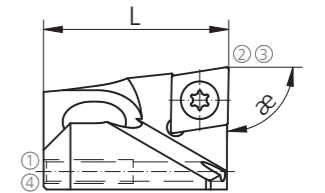

RFP = Roughing-Finishing-Process

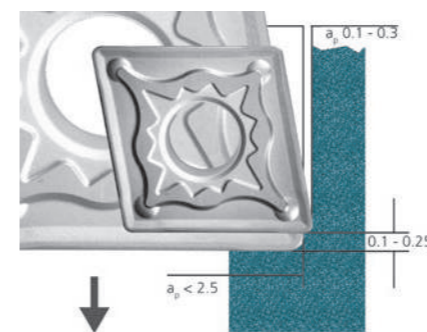

Preajuste del filo para desbaste y acabado
Descripción mirar página 57
Presetting of roughing and finishing cutting edge
Description see page 57

Aplicable simultaneamente con porta placas de desbaste W17 00 12P (página 72)
Simultaneously applicable with roughing insert holder W17 00 12P (page 72)

SPARE PARTS

①	②	③	④
CP../CC.. 0602..	G00 02 02	C00 20 01	G00 20 05
CC.. 09T3..	G00 02 02	C00 20 02	G00 20 03
			C00 02 12

Ø 150 - 805 mm

Extensores de diámetro

Diameter extenders

Extensores de diámetro hecho de acero

Diameter extenders made of steel

Order Number	Ø-range	L	I	D	kg	MCM	MCC	Index
Z2 00 13	150 - 205	30	105	130	1,8	Z2200	K00	●
Z2 00 18	200 - 255	30	105	180	2,6	Z2200	K00	●
Z2 00 23	250 - 305	35	110	230	4	Z2200	K00	●

otras medidas disponibles bajo demanda

further dimensions available on request

Extensores de diámetro hecho de aluminio

Diameter extenders made of aluminium

Order Number	Ø-range	L	I	D	kg	MCM	MCC	Index
L22 00 23	250 - 305	55	130	230	2,8	Z2200	K00	●
L22 00 28	300 - 355	55	130	280	3,3	Z2200	K00	●
L22 00 33	350 - 405	55	130	330	3,8	Z2200	K00	●
L22 00 38	400 - 455	55	130	380	4,3	Z2200	K00	●
L22 00 43	450 - 505	55	130	430	4,8	Z2200	K00	●
L22 00 48	500 - 555	65	140	480	6,1	Z2200	K00	●
L22 00 53	550 - 605	65	140	530	6,7	Z2200	K00	●
L22 00 58	600 - 655	65	140	580	7,3	Z2200	K00	●
L22 00 63	650 - 705	65	140	630	8,9	Z2200	K00	●
L22 00 68	700 - 755	65	140	680	9,6	Z2200	K00	●
L22 00 73	750 - 805	65	140	730	10,2	Z2200	K00	●

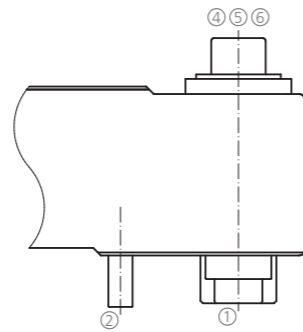
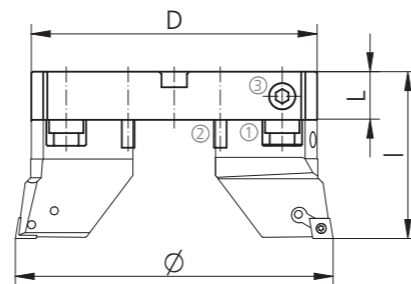

a partir Ø = 250
from Ø = 250

SPARE PARTS

D	①	②	③	④	⑤	⑥
130-180	Z00 22 24	Z00 22 21	Z00 22 23			
230 steel	Z00 22 16	Z00 22 21		Z00 22 15	C00 24 04	K00 02 06
230-280	Z00 22 16	Z00 22 21		Z00 22 15	C00 24 04	K00 02 06
480-805	Z00 22 16	Z00 22 21		Z00 22 15	C00 26 09	K00 02 06

Ø 150 - 805 mm

Conos/Adaptadores directos

Direct adaptors

DIN 69871-A/D

Order Number	◁	L	D	kg	MCC	Index
D11 50 02	50	85	130	5,6	Z2200	●

DIN 69871B

Order Number	◁	L	D	kg	MCC	Index
H11 53 02	50	85	130	5,6	Z2200	●

MAS-BT

Order Number	◁	L	D	kg	MCC	Index
T11 51 02	50	88	130	5,6	Z2200	●

DIN 69893A HSK

Order Number	◁	L	D	kg	MCC	Index
HSKA11 100 02*	100	72	130	4,4	Z2200	●

* El tubo de la refrigeración no está incluido
Coolant tube is not included

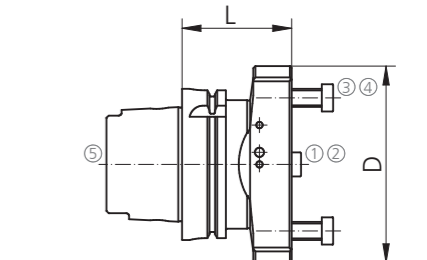
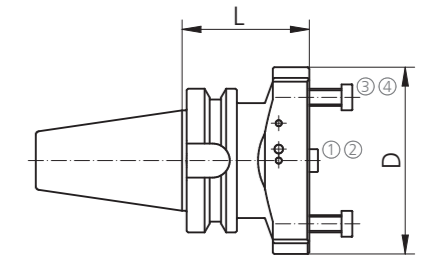
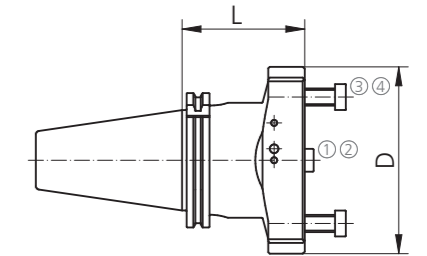
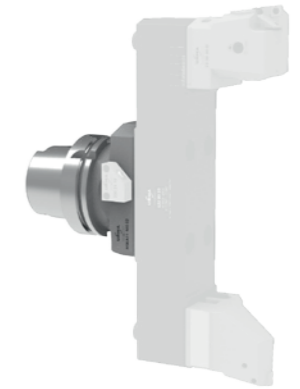

SPARE PARTS

①	②	③	④	⑤
Z00 21 02	C00 22 27	C00 22 03	G00 02 19	H00 100 01

Boquilla de la refrigeración ver páginas 78 y 79
Coolant nozzle see pages 78 and 79

Ø 150 - 805 mm

Adaptador intermedio
Intermediate adaptors



Adaptador intermedio
Intermediate adaptors

Alpha	Order Number	L	D	d	MCM	MCC	Index
94	21 94 01	55	130	94	94	Z2200	●

⑦ **No incluido en la entrega**
Not included in the delivery

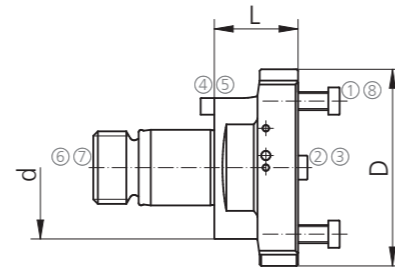

Boquilla de la refrigeración
Coolant nozzle

Alpha	Order Number	MCC	Index
94	Z00 21 10	Z0021	●

2 piezas por adaptador intermedio necesarias
2 pieces per intermediate adaptor necessary

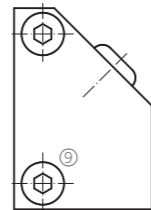

SPARE PARTS

Alpha	①	②	③	④	⑤	⑥	⑦	⑧	⑨
94	C00 22 03	Z00 21 02	C00 22 27	Z00 00 94	C00 24 17	Z00 14 96	53 74 96	G00 02 19	C00 22 05

Ø 150 - 805 mm

Adaptador intermedio
Intermediate adaptors



Adaptador intermedio
Intermediate adaptors

Beta	Order Number	L	D	d	kg	MCM	MCC	Index
100	B21 100 01 055	55	130	100	4,7	B100	Z2200	●

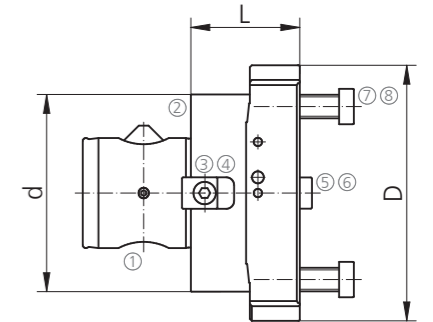

Boquilla de la refrigeración
Coolant nozzle

Beta	Order Number	MCC	Index
100	Z00 21 10	Z0021	●

2 piezas por adaptador intermedio necesarias
2 pieces per intermediate adaptor necessary

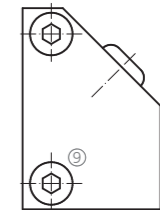

SPARE PARTS

Beta	①	②	③	④	⑤	⑥	⑦	⑧	⑨
100	Z00 100 21	Z00 100 23	Z00 100 25	C00 22 71	Z00 21 02	C00 22 27	C00 22 03	G00 02 19	C00 22 05

URMA Systems
SuperMegaMax

Ø 500 - 2'400 mm

Ø 500 - 2'400 mm

SuperMegaMax

DIGITEC

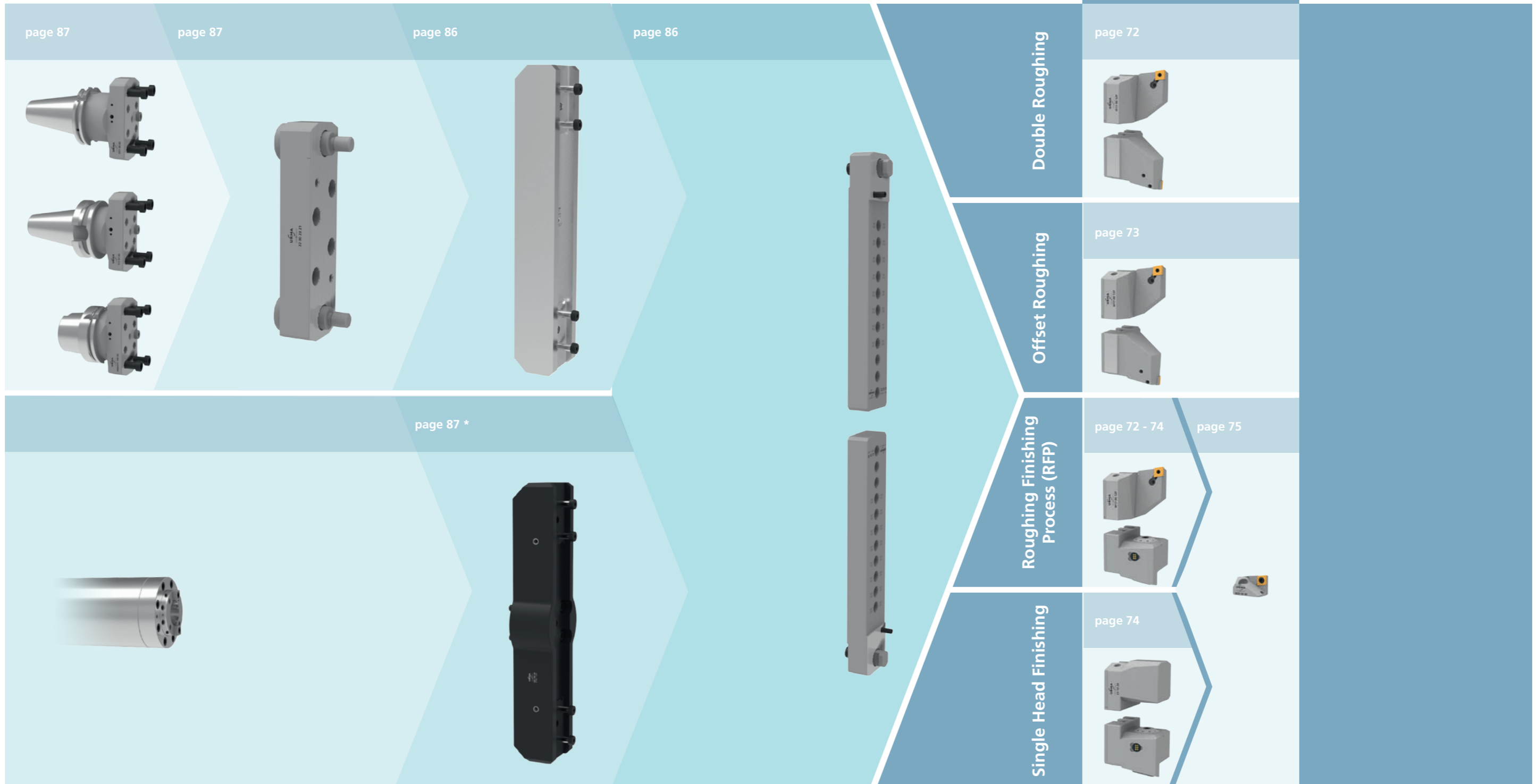

* a pedido; es altamente recomendado amarrar las herramientas a la nariz del husillo on request; it is highly recommended to bolt the tools to the spindle nose

Ø 500 - 2'400 mm

Amarre SuperMegaMax
Assembling SuperMegaMax

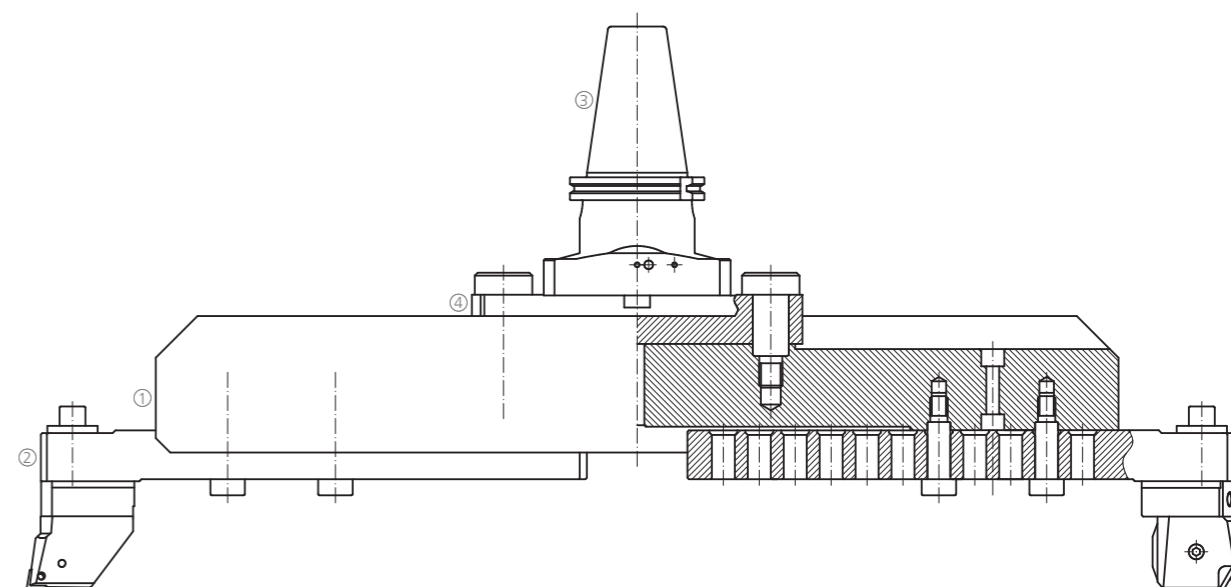

- ① **Adaptador (aluminium)**
Adaptor (aluminium)
- ② **Extensor de diámetro**
Diameter extender
- ③ **Cono**
Tool holder
- ④ **Extensor de diámetro con perno de bloqueo especial**
Diameter extender with special lock stud

datos de corte bajo demanda
cutting data on request

Ø 500 - 2'400 mm



Adaptador / extensor de diámetro
Adaptor / Diameter extender

Adaptador (aluminium)
Adaptor (aluminium)

Order Number	Ø-range	L	I	S	kg	Index
21 20 05 *	500 - 700	350	50	65	6	●
21 20 07 *	700 - 900	550	60	75	12	●
21 20 10	800 - 1200	670	60	95	17	●
21 20 11	1200 - 1600	1070	60	95	28	●
21 20 12	1600 - 2000	1470	115	150	64	●
21 20 13	2000 - 2400	1870	115	150	81.5	●

* **Amarrado directamente al cono**
Directly assembled to the tool holder

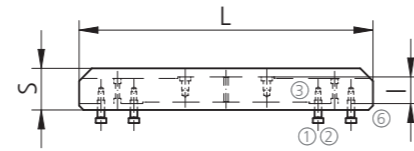

Extensor de diámetro
Diameter extender

Order Number	Ø-range	kg	Index
22 00 05	500 - 900	6.3	●
22 20 10	800 - 2400	8	○

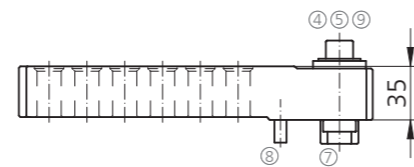

Información sobre porta placas p. 72, display p. 17, cabezales de acabado p. 74, porta placas acabado p. 75, contrapeso p. 74 y boquilla refrigerante p. 78
Information about insert holder p. 72, display unit p. 17, fine boring heads p. 74, fine boring insert holders p. 75, counterweight p. 74 and coolant nozzle p. 78

SPARE PARTS

	1	2	3	4	5	6	7	8	9
21 20 05	G00 02 08	C00 23 02							
21 20 07	G00 02 08	C00 23 02							
21 20 10	G00 02 08	C00 23 02							
21 20 11	G00 02 08	C00 23 02							
21 20 12	G00 02 08	C00 23 02	C00 96 13	C00 23 48	Z00 21 13	22 20 13			
21 20 13	G00 02 08	C00 23 02	C00 96 13	C00 22 92	Z00 21 13	22 20 13			
22 00 05				C00 24 04	Z00 22 15		Z00 22 16	Z00 22 21	K00 02 06
22 20 10				C00 24 04	Z00 22 15		Z00 22 16	Z00 22 21	K00 02 06

Ø 500 - 2'400 mm



Cono / extensor de diámetro
Tool holder / Diameter extender

Cono *
Tool holder *

Order Number	Ø-range		L	D	kg	Index
D11 50 02	500 - 2400	DIN 69871 A	50	85	130	5.6 ●
H11 53 02	500 - 2400	DIN 69871 B	50	85	130	5.6 ●
T11 51 02	500 - 2400	MAS-BT	50	88	130	5.6 ●
HSKA11 100 02	500 - 2400	DIN 69893 A	100	72	130	4.4 ●

* **Es altamente recomendable amarrar las herramientas a la nariz del husillo. Adaptadores bajo demanda.**
It is highly recommended to bolt the tools to the spindle nose
Adaptors on request

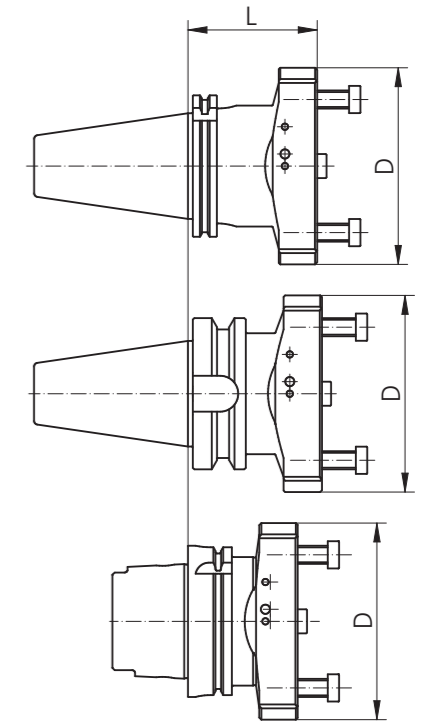

Extensor de diámetro con perno de bloqueo especial
Diameter extender with special lock stud

Order Number	Ø-range	L	kg	Index
22 00 23 21	800 - 1600	35	5	●
22 00 43 21	1600 - 2400	40	9.7	●

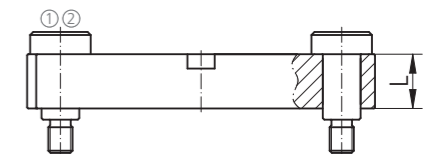

SPARE PARTS

	1	2
Z00 21 21	G00 02 10	

URMA Systems

LBS-System

Ø 20 - 51 mm

Ø 20 - 51 mm

Sistema LBS
LBS-System

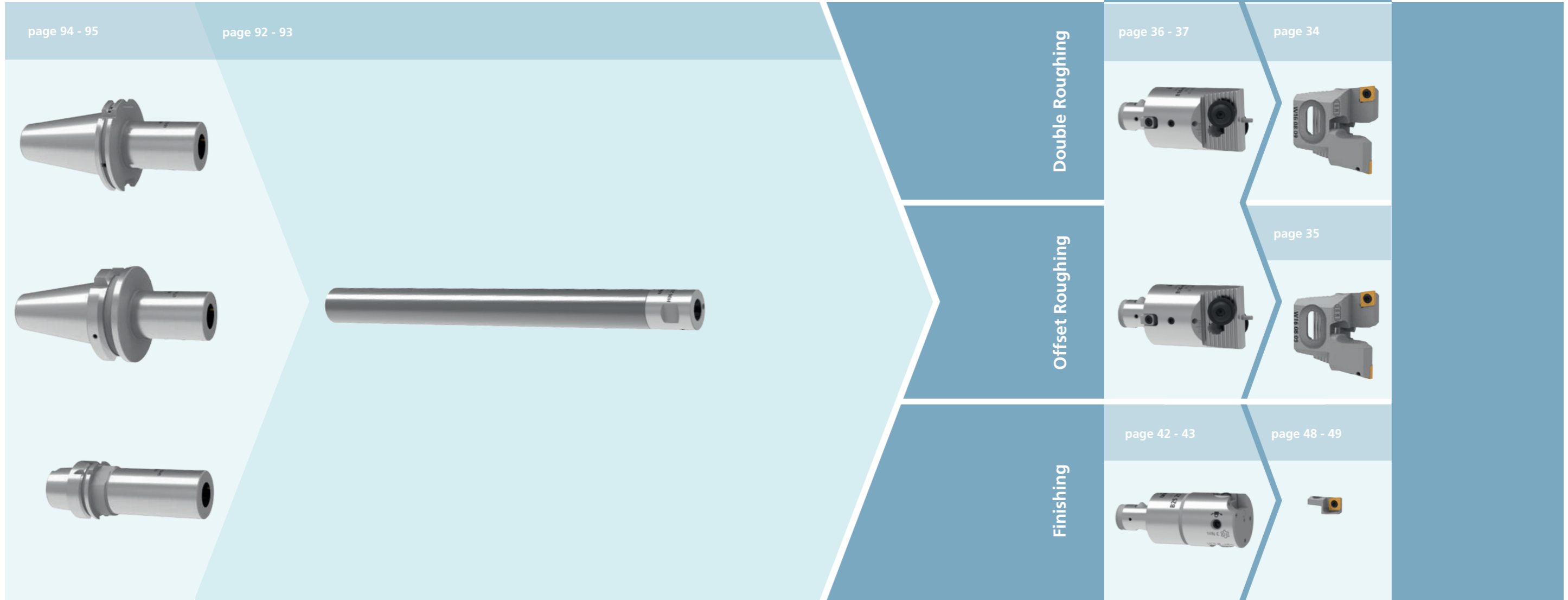

Ø 20 - 51 mm

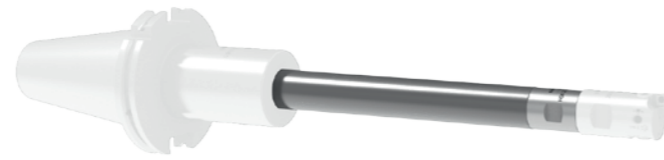

Barras de metal duro para mandrinar
Carbide boring bars

Barras de metal duro para mandrinar
Carbide boring bars

Alpha	Order Number	Ø-range	L	I	D	kg	SW	MCM	MCC	Index
18,5	H06 18 A18 200	20 - 30	200	139 - 185	18,5	0,65	17	ZS18,5	18,5	●
25	H06 25 A24 234	29 - 39	234	167 - 209	25	1,4	22	ZS25	24,5	●
25	H06 25 A24 276	29 - 39	276	209 - 251	25	1,7	22	ZS25	24,5	●
32	H06 32 A32 351	38 - 51	351	240 - 320	32	3,5	27	ZS25	32	●

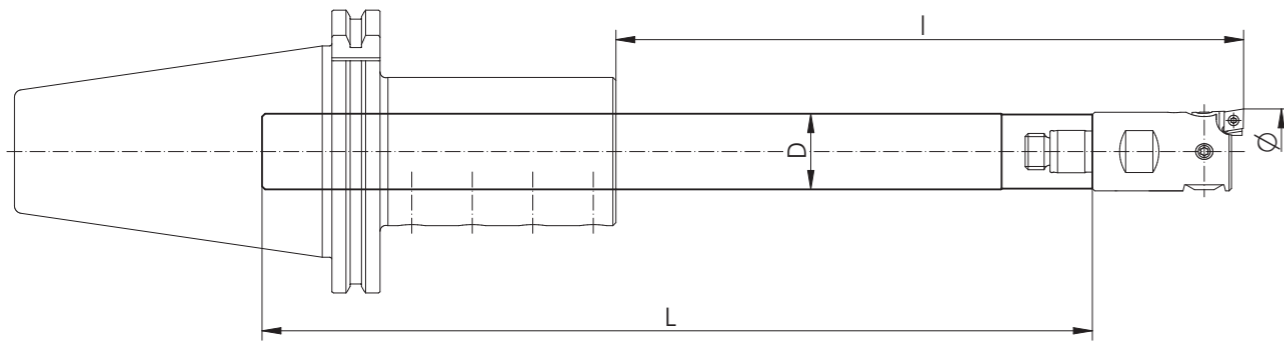

El sistema LBS es valido tanto para acabado como para desbaste
The LBS-System is suitable for both roughing and finishing

Ver cabezas de acabado disponibles en las páginas 42 y 46, cabezas de doble corte para desbaste en la página 36
Suitable fine boring heads see pages 42 and 46, double cutter roughing heads see page 36

Ø 29 - 51 mm

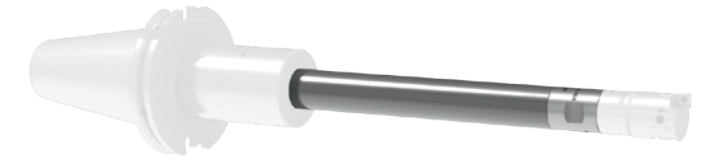

Barras de metal duro para mandrinar
Carbide boring bars

Barras de metal duro para mandrinar
Carbide boring bars

Beta	Order Number	Ø-range	L	I	D	kg	SW	MCM	MCC	Index
25	H06 25 B25 234	29 - 39	234	167 - 209	25	1,4	22	ZS25	B25	●
25	H06 25 B25 276	29 - 39	276	209 - 251	25	1,7	22	ZS25	B25	●
32	H06 32 B32 351	38 - 51	351	240 - 320	32	3,5	27	ZS32	B32	●

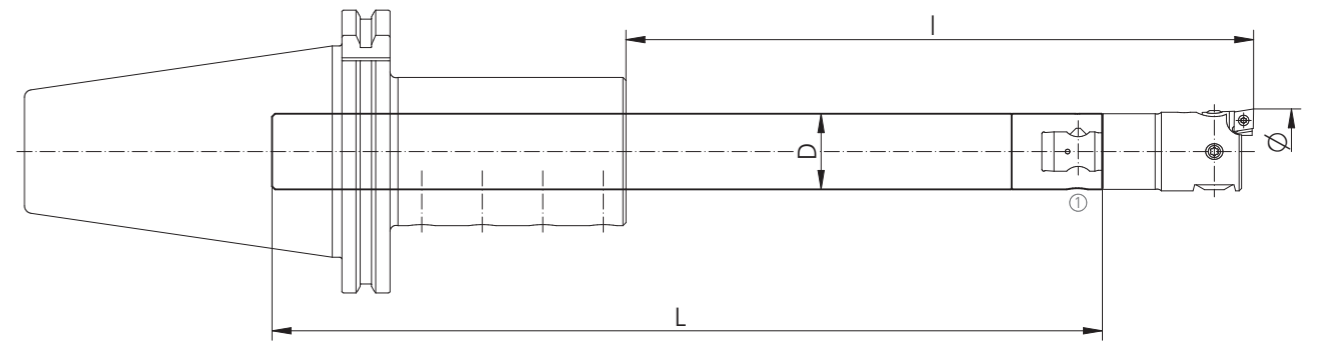

El sistema LBS es valido tanto para acabado como para desbaste
The LBS-System is suitable for both roughing and finishing

Ver cabezas de acabado disponibles en las páginas 43 y 47, cabezas de doble corte para desbaste en la página 37
Suitable Fine boring heads see pages 43 and 47, double cutter roughing heads see page 37

SPARE PARTS

Beta	①
25	Z00 25 24
32	Z00 32 24

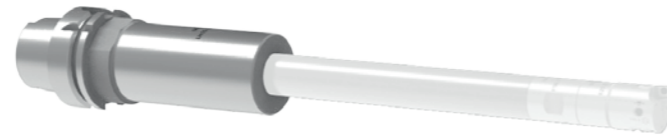

Conos LBS
LBS-Tool holders

Conos MAS-BT
Tool holders MAS-BT

Order Number	L	I	D	d	□	MCC	Index
LT10 41 18 040	67	40	44	18,5	MAS-BT-A/40	ZS18,5	●
LT10 43 18 040	67	40	44	18,5	MAS-BT-B/40	ZS18,5	●●
LT10 51 18 060	98	60	44	18,5	MAS-BT-A/50	ZS18,5	●●
LT10 53 18 060	98	60	44	18,5	MAS-BT-B/50	ZS18,5	●●
LT10 41 25 057	84	57	49	25	MAS-BT-A/40	ZS25	●●
LT10 43 25 057	84	57	49	25	MAS-BT-B/40	ZS25	●●
LT10 51 25 078	116	78	49	25	MAS-BT-A/50	ZS25	●●
LT10 53 25 078	116	78	49	25	MAS-BT-B/50	ZS25	●●
LT10 51 32 095	133	95	60	32	MAS-BT-A/50	ZS32	●●
LT10 53 32 095	133	95	60	32	MAS-BT-B/50	ZS32	●●

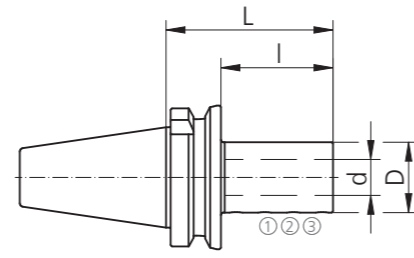

Conos DIN 69893-A
Tool holders HSK

Order Number	L	I	D	d	□	MCC	Index
LH10 63 18 101	127	85	44	18,5	HSK 63-A	ZS18,5	●
LH10 63 25 117	143	101	49	25	HSK 63-A	ZS25	●●
LH10 100 18 107	152	107	44	18,5	HSK 100-A	ZS18,5	●●
LH10 100 25 159	204	159	49	25	HSK 100-A	ZS25	●●
LH10 100 32 170	215	170	60	32	HSK 100-A	ZS32	●●

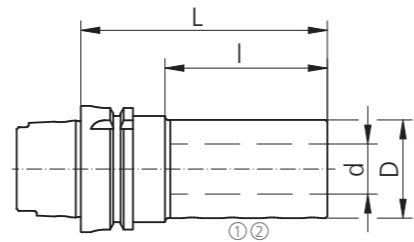

SPARE PARTS

d	①	②	③
18,5	G00 02 05	C00 96 10	
25	G00 02 05		Z00 10 91
32	G00 02 06	C00 96 11	

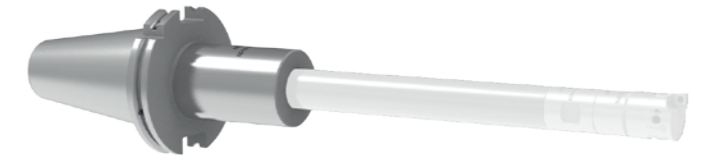

Conos LBS
LBS-Tool holders

Conos DIN 69871
Tool holders DIN 69871

Order Number	L	I	D	d	□	MCC	Index
LD10 41 18 042	61	42	44	18.5	DIN 69871-A/40	ZS18,5	●
LD10 43 18 042	61	42	44	18.5	DIN 69871-B/40	ZS18,5	●●
LD10 50 18 060	79	60	44	18.5	DIN 69871-A/50	ZS18,5	●●
LD10 53 18 060	79	60	44	18.5	DIN 69871-B/50	ZS18,5	●●
LD10 41 25 059	79	59	49	25	DIN 69871-A/40	ZS25	●●
LD10 43 25 059	79	59	49	25	DIN 69871-B/40	ZS25	●●
LD10 50 25 078	98	78	49	25	DIN 69871-A/50	ZS25	●●
LD10 53 25 078	98	78	49	25	DIN 69871-B/50	ZS25	●●
LD10 50 32 095	114	95	60	32	DIN 69871-A/50	ZS32	●●
LD10 53 32 095	114	95	60	32	DIN 69871-B/50	ZS32	●●

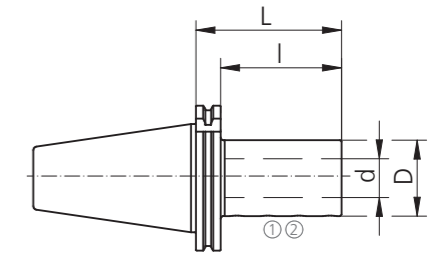

SPARE PARTS

d	①	②
18,5	G00 02 05	C00 96 10
25	G00 02 05	C00 96 10
32	G00 02 06	C00 96 11

URMA Systems

Modular Components

Componentes modulares
Modular components

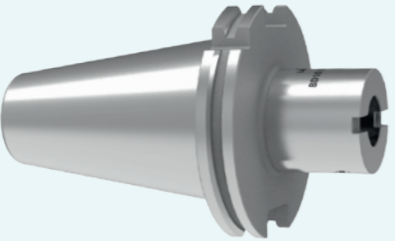
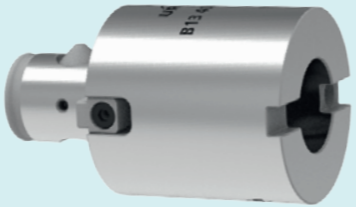
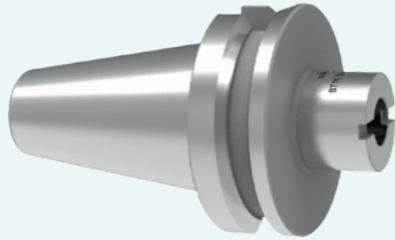
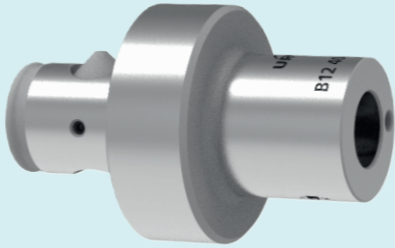
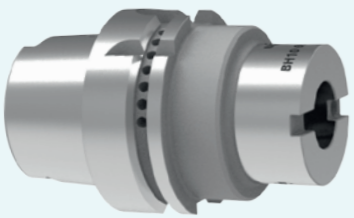
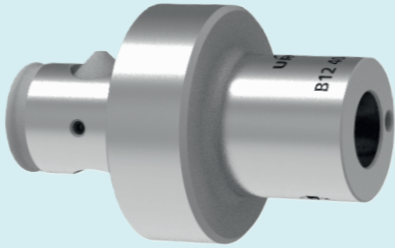
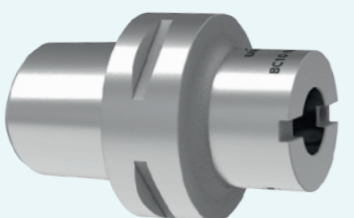
page 104 - 113	page 100 - 101	DigiTec	page 11
		MicroMax	page 19
		VersaMax - Type 14	page 29
	page 102 - 103	VersaMax - Type 25 / Type A25	page 39
		IntraMax	page 51
		MegaMax	page 69
		SuperMegaMax	page 81



Extensores

Extensions

Extensores

Extensions

Alpha	Order Number	L	D	kg	SW	MCM	MCC	Index
18,5	13 18 01	25	18,5	0,1	17	18,5	18,5	●
18,5	13 18 11	35	18,5	0,1	17	18,5	18,5	●●
24,5	13 24 01	30	24,5	0,1	22	24,5	24,5	●●
24,5	13 24 11	45	24,5	0,2	22	24,	24,5	●●
32	13 32 01	40	32	0,2	27	32	32	●●
32	13 32 11	60	32	0,3	27	32	32	●●
42	13 42 01	50	42	0,5	36	42	42	●●
42	13 42 11	80	42	0,8	36	42	42	●●
55	13 55 01	70	55	1,2	46	55	55	●●
55	13 55 11	105	55	1,5	46	55	55	●●
72	13 72 01*	75	72	2,2	60	72	72	●●
94	13 94 01*	100	94	5,1	75	94	94	●●

* con chaveta de anclaje
supplied with a driving key

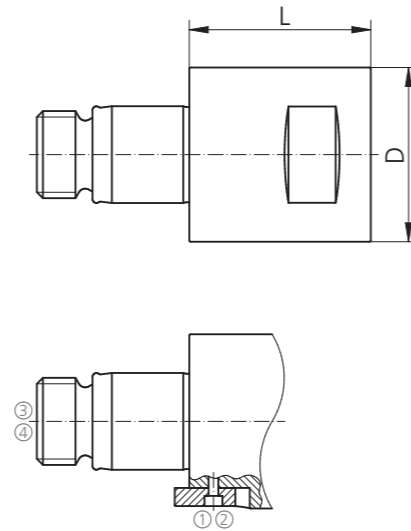

④ No incluido en la entrega
Not included in the delivery

SPARE PARTS

Alpha	Beta	①	②	③	④
72	80	Z00 00 72	C00 22 11	Z00 14 74	53 74 96
94	100	Z00 00 94	C00 24 17	Z00 14 96	53 74 96



Extensores

Extensions

Extensores Beta-Beta

Extensions Beta-Beta

Beta	Order Number	L	D	kg	MCM	MCC	Index
25	B13 25 25 045	45	25	0,2	B25	B25	●
25	B13 25 25 070	70	25	0,3	B25	B25	●●
32	B13 32 32 035	35	32	0,2	B32	B32	●●
32	B13 32 32 070	70	32	0,4	B32	B32	●●
40	B13 40 40 045	45	42	0,4	B42	B42	●●
40	B13 40 40 070	70	42	0,7	B42	B42	●●
50	B13 50 50 065	65	50	1,0	B50	B50	●●
50	B13 50 50 100	100	50	1,5	B50	B50	●●
63	B13 63 63 060	60	63	1,3	B63	B63	●●
63	B13 63 63 125	125	63	2,9	B63	B63	●●
80	B13 80 80 080	80	80	2,9	B80	B80	●●
80	B13 80 80 160	160	80	6,1	B80	B80	●●
100	B13 100 100 080	80	100	4,9	B100	B100	●●
100	B13 100 100 180	180	100	10,9	B100	B100	●●

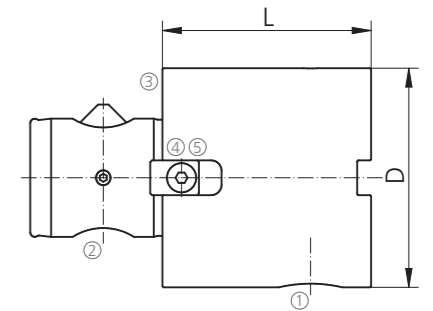

SPARE PARTS

Beta	①	②	③	④	⑤
25	Z00 25 24	Z00 25 21	Z00 25 23		
32	Z00 32 24	Z00 32 21	Z00 32 23		
40	Z00 40 24	Z00 40 21	Z00 40 23	Z00 40 25	C00 22 58
50	Z00 50 24	Z00 50 21	Z00 50 23	Z00 50 25	C00 22 60
63	Z00 63 24	Z00 63 21	Z00 63 23	Z00 63 25	C00 22 05
80	Z00 80 24	Z00 80 21	Z00 80 23	Z00 80 25	C00 22 07
100	Z00 100 24	Z00 100 21	Z00 100 23	Z00 100 25	C00 22 71



Reductores

Reducers

Reductores

Reducers

Alpha	Alpha 1	Order Number	L	I	D	d	kg	SW	MCM	MCC	Index
24,5	18,5	12 24 02	30	15	18,5	24,5	0,1	22	24,5	18,5	●
24,5	18,5	12 24 03	55	40	18,5	24,5	0,2	22	24,5	18,5	●
32	18,5	12 32 02	30	15	18,5	32	0,2	27	32	18,5	●
32	24,5	12 32 07	40	25	24,5	32	0,3	27	32	24,5	●
32	24,5	12 32 08	70	55	24,5	32	0,3	27	32	24,5	●
42	18,5	12 42 02	35	15	18,5	42	0,4	36	42	18,5	●
42	24,5	12 42 07	45	25	24,5	42	0,4	36	42	24,5	●
42	32	12 42 12	45	25	32	42	0,4	36	42	32	●
42	32	12 42 13	85	65	32	42	0,7	36	42	32	●
55	18,5	12 55 02	40	15	18,5	55	0,7	46	55	18,5	●
55	24,5	12 55 07	50	25	24,5	55	0,7	46	55	24,5	●
55	32	12 55 12	50	25	32	55	0,7	46	55	32	●
55	42	12 55 17	55	30	42	55	0,8	46	55	42	●
55	42	12 55 18	105	80	42	55	1,3	46	55	42	●
72	42	12 72 17	60	30	42	72	1,6	60	72	42	●
72	55	12 72 22	60	30	55	72	1,7	60	72	55	●
94	55	12 94 22	65	30	55	94	3,1	75	94	55	●
94	72	12 94 27*	80	45	72	94	3,5	75	94	72	●

* con chaveta de anclaje
supplied with a driving key

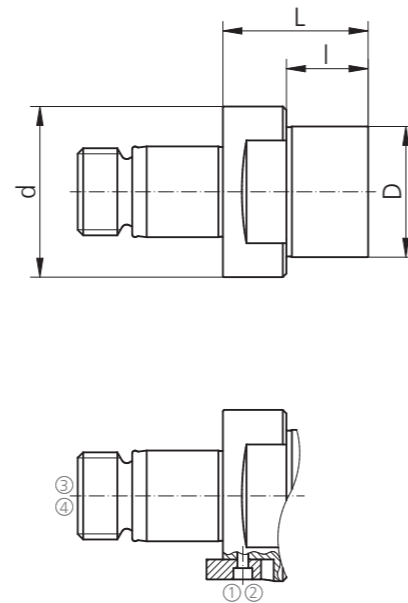

④ No incluido en la entrega
Not included in the delivery

SPARE PARTS

Alpha	①	②	③	④
94	Z00 00 94	C00 24 17	Z00 14 96	53 74 96



Reductores

Reducers

Reductores Beta-Beta

Reducers Beta-Beta

Beta	Beta 1	Order Number	L	I	D	d	kg	SW	MCM	MCC	Index
32	25	B12 32 25 040	40	25	25	32	0,2		B32	B25	●
40	25	B12 40 25 040	40	25	25	42	0,3		B40	B25	●
40	32	B12 40 32 045	45	30	32	42	0,3		B40	B32	●
50	40	B12 50 40 050	50	35	42	50	0,5		B50	B40	●
63	25	B12 63 25 045	45	25	25	63	0,7		B63	B25	●
63	32	B12 63 32 050	50	30	32	63	0,9		B63	B32	●
63	40	B12 63 40 055	55	35	42	63	1,1		B63	B40	●
63	50	B12 63 50 060	60	40	50	63	1,1		B63	B50	●
80	40	B12 80 40 060	60	35	42	80	2,2		B80	B40	●
80	63	B12 80 63 060	60	35	63	80	2,4		B80	B63	●
100	63	B12 100 63 060	60	35	63	100	3,3		B100	B63	●
100	80	B12 100 80 075	75	50	80	100	3,5		B100	B80	●

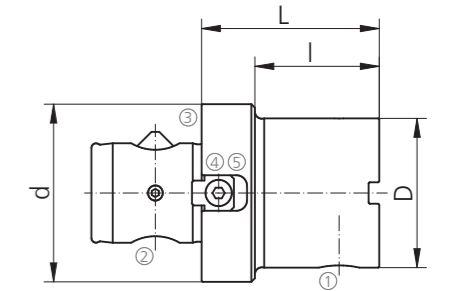

Reductores Beta-Alpha

Reducers Beta-Alpha

Beta	Alpha	Order Number	L	I	D	d	kg	SW	MCM	MCC	Index
25	18,5	B12 25 18 040	40	25	18,5	25	0,1	17	B25	18,5	●
32	18,5	B12 32 18 040	40	25	18,5	32	0,1	17	B32	18,5	●
40	18,5	B12 40 18 040	40	25	18,5	42	0,2	17	B40	18,5	●

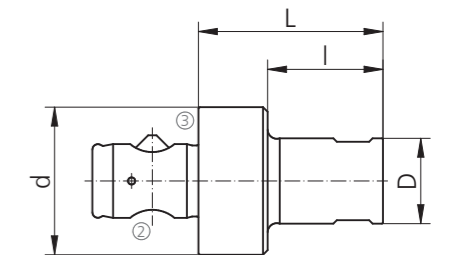

SPARE PARTS

Beta	①	②	③	④	⑤
25	Z00 25 24	Z00 25 21	Z00 25 23		
32	Z00 32 24	Z00 32 21	Z00 32 23		
40	Z00 40 24	Z00 40 21	Z00 40 23	Z00 40 25	C00 22 58
50	Z00 50 24	Z00 50 21	Z00 50 23	Z00 50 25	C00 22 60
63	Z00 63 24	Z00 63 21	Z00 63 23	Z00 63 25	C00 22 05
80	Z00 80 24	Z00 80 21	Z00 80 23	Z00 80 25	C00 22 07
100	Z00 100 24	Z00 100 21	Z00 100 23	Z00 100 25	C00 22 71

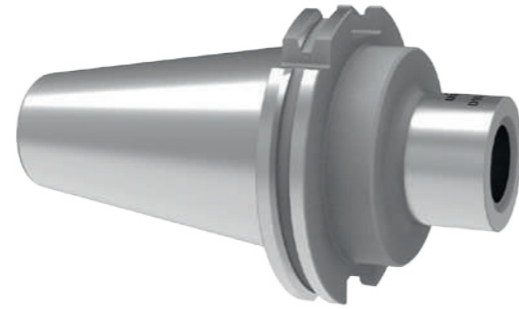

Conos de sistema
System adaptors

Conexión axial roscada
With axial threaded connection

DIN 69871-A/D

Alpha	Order Number	▽	L	I	D	kg	MCC	Index
42	D10 31 16	30	35	16	42	0,8	42	●
18,5	D10 41 03	40	75	40	18,5	1,1	18,5	●
24,5	D10 41 07	40	60	25	24,5	1,1	24,5	●
24,5	D10 41 08	40	90	55	24,5	1,2	24,5	●
32	D10 41 12	40	60	25	32	1,1	32	●
32	D10 41 13	40	100	65	32	1,4	32	●
42	D10 41 16	40	35	16	42	1,2	42	●
42	D10 41 17	40	65	30	42	1,3	42	●
55	D10 41 22	40	65	46	55	1,2	55	●
24,5	D10 50 07	50	60	25	24,5	3,2	24,5	●
32	D10 50 12	50	60	25	32	3,2	32	●
42	D10 50 17	50	65	30	42	4,0	42	●
55	D10 50 22	50	65	30	55	3,3	55	●
72	D10 50 27	50	80	61	72	3,7	72	●
94	D10 50 32	50	85	66	94	4,0	94	●

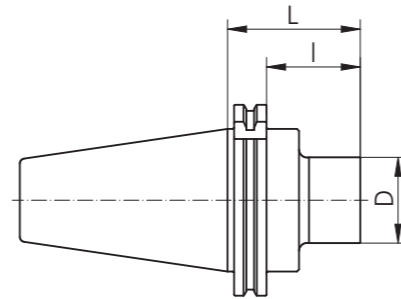

DIN 69871-B

Alpha	Order Number	▽	L	I	D	kg	MCC	Index
42	H10 43 16	40	35	16	42	1,2	42	●
55	H10 43 22	40	65	46	55	1,2	55	●
42	H10 53 17	50	65	30	42	4,0	42	●
55	H10 53 22	50	65	30	55	3,3	55	●
72	H10 53 27	50	80	61	72	3,7	72	●
94	H10 53 32	50	85	66	94	4,0	94	●

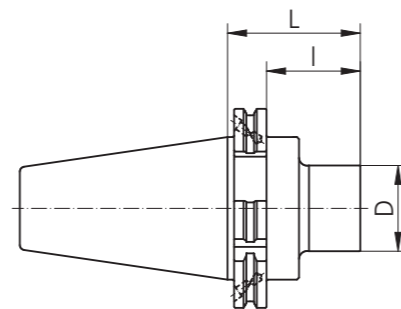

D = 72 mm con un chavetero
D = 94 mm con dos chaveteros
D = 72 mm with one driving keyway
D = 94 mm with two driving keyways

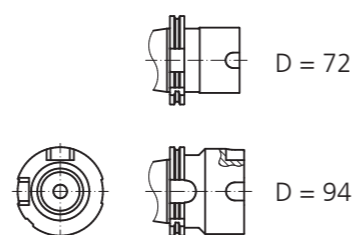

Conos de sistema
System adaptors

Sistema de bloqueo lateral
With side lock system

DIN 69871-A/D

Beta	Order Number	▽	L	I	D	kg	MCC	Index
25	BD10 40A 25 050	40	50	31	25	0,8	B25	●
32	BD10 40A 32 050	40	50	31	32	0,9	B32	●
40	BD10 40A 40 035	40	35	16	42	0,9	B40	●
40	BD10 40A 40 050	40	50	31	42	1,1	B40	●
50	BD10 40A 50 050	40	50	31	50	1,2	B50	●
63	BD10 40A 63 065	40	65	46	63	1,5	B63	●
25	BD10 50A 25 060	50	60	41	25	2,8	B25	●
32	BD10 50A 32 060	50	60	41	32	2,9	B32	●
40	BD10 50A 40 060	50	60	41	42	3,0	B40	●
50	BD10 50A 50 060	50	60	41	50	3,2	B50	●
63	BD10 50A 63 060	50	60	41	63	3,3	B63	●
80	BD10 50A 80 070	50	70	51	80	4,0	B80	●
100	BD10 50A 100 115	50	115	96	100	6,9	B100	●

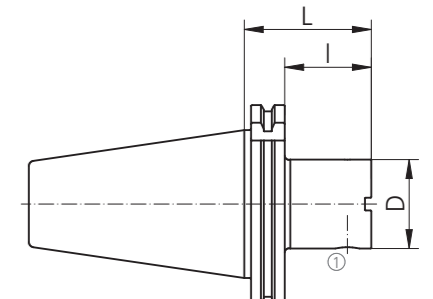

DIN 69871-B

Beta	Order Number	▽	L	I	D	kg	MCC	Index
40	BD10 40B 40 035	40	35	16	42	0,9	B40	●
63	BD10 40B 63 065	40	65	46	63	1,5	B63	●
40	BD10 50B 40 060	50	60	41	42	3,0	B40	●
50	BD10 50B 50 060	50	60	41	50	3,2	B50	●
63	BD10 50B 63 060	50	60	41	63	3,3	B63	●
100	BD10 50B 100 115	50	115	96	100	6,9	B100	●

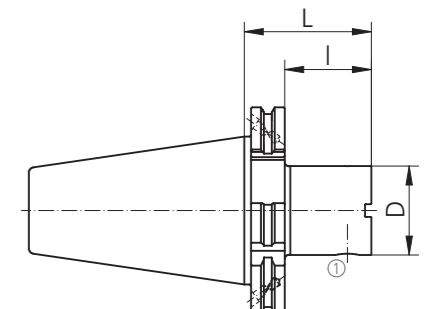

SPARE PARTS

Beta	Order Number
25	Z00 25 24
32	Z00 32 24
40	Z00 40 24
50	Z00 50 24
63	Z00 63 24
80	Z00 80 24
100	Z00 100 24



Conos de sistema
System adaptors

Conexión axial roscada
With axial threaded connection

MAS-BT-A

Alpha	Order Number	▽	L	I	D	kg	MCC	Index
42	T10 31 16	30	32	10	42	0,8	42	○
18,5	T10 41 03	40	67	40	18,5	1,0	18,5	●
24,5	T10 41 07	40	52	25	24,5	1,0	24,5	●
32	T10 41 12	40	52	25	32	1,0	32	●
42	T10 41 16	40	29	2	42	1,0	42	●
42	T10 41 17	40	57	30	42	1,1	42	●
55	T10 41 22	40	57	30	55	1,2	55	●
32	T10 51 13	50	103	65	32	4,0	32	●
42	T10 51 17	50	68	30	42	3,3	42	●
55	T10 51 22	50	68	30	55	3,8	55	●
72	T10 51 27	50	83	45	72	4,2	72	●
94	T10 51 32	50	88	50	94	4,5	94	●

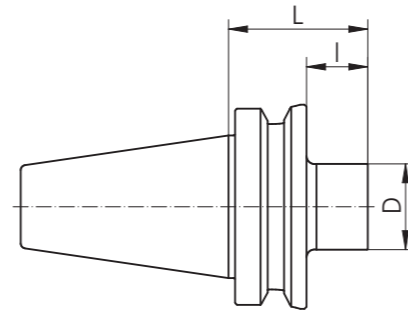

D = 72 mm con un chavetero
D = 94 mm con dos chaveteros
D = 72 mm with one driving keyway
D = 94 mm with two driving keyways

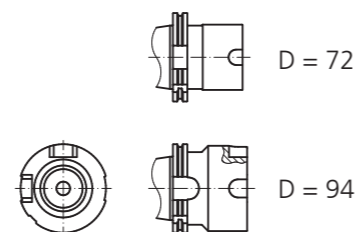

Conos de sistema
System adaptors

Sistema de bloqueo lateral
With side lock system

MAS-BT-A

Beta	Order Number	▽	L	I	D	kg	MCC	Index
25	BT10 40A 25 060	40	60	33	25	0,8	B25	●
32	BT10 40A 32 060	40	60	33	32	0,9	B32	●
40	BT10 40A 40 028	40	28	1	42	0,9	B40	●
40	BT10 40A 40 060	40	60	33	42	1,2	B40	●
50	BT10 40A 50 060	40	60	33	50	1,3	B50	●
63	BT10 40A 63 055	40	55	28	63	1,4	B63	●
32	BT10 50A 32 070	50	70	32	32	3,7	B32	●
40	BT10 50A 40 070	50	70	32	42	3,9	B40	●
50	BT10 50A 50 070	50	70	32	50	4,1	B50	●
63	BT10 50A 63 080	50	80	42	63	4,3	B63	●
80	BT10 50A 80 100	50	100	62	80	5,5	B80	●
100	BT10 50A 100 110	50	110	72	100	7,0	B100	●

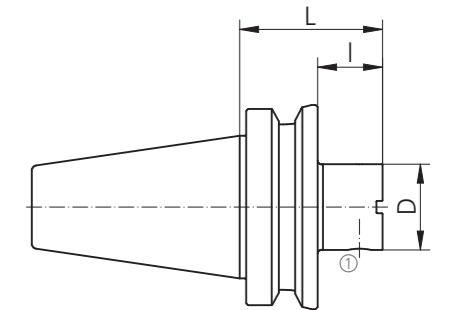

SPARE PARTS

Beta	①
25	Z00 25 24
32	Z00 32 24
40	Z00 40 24
50	Z00 50 24
63	Z00 63 24
80	Z00 80 24
100	Z00 100 24

Conos de sistema URMA-FT

System adaptors URMA-FT

Sistema de bloqueo lateral

With side lock system

**Para mejorar la rigidez y mayor rendimiento de las herramientas
Equivalente a sistemas existentes**

For improved rigidity and higher cutting performance
Equivalent to existing systems

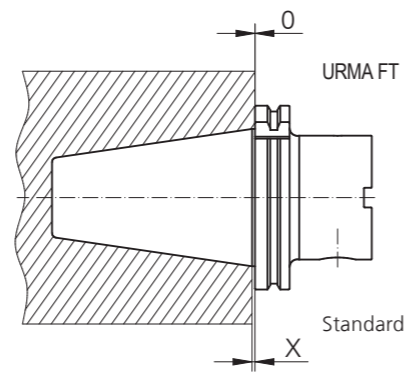

DIN 69871-A

Beta	Order Number		L	I	D	kg	MCC	Index
40	BDP10 50A 40 060	50	60	41	42	3,0	B40	●
63	BDP10 50A 63 060	50	60	41	63	3,3	B63	●
80	BDP10 50A 80 070	50	70	51	80	4,0	B80	●
100	BDP10 50A 100 115	50	115	96	100	6,9	B100	●

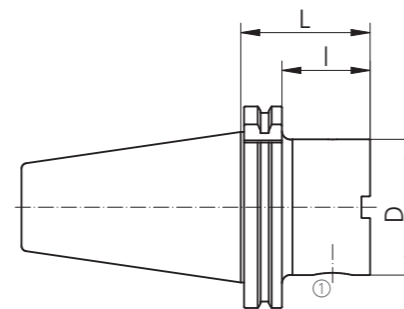

SPARE PARTS

Beta		Order Number
40		Z00 40 24
63		Z00 63 24
80		Z00 80 24
100		Z00 100 24

Conos de sistema URMA-FT

System adaptors URMA-FT

Sistema de bloqueo lateral

With side lock system

**Para mejorar la rigidez y mayor rendimiento de las herramientas
Equivalente a sistemas existentes**

For improved rigidity and higher cutting performance
Equivalent to existing systems

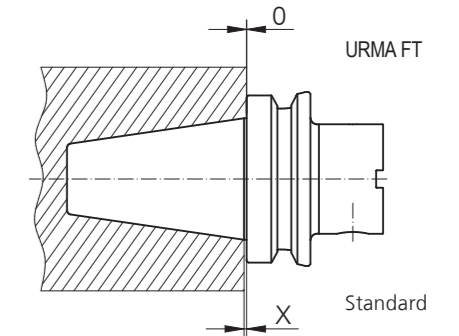

MAS-BT-A

Beta	Order Number		L	I	D	kg	MCC	Index
40	BTP10 40A 40 028	40	28	1	42	0,9	B40	●
63	BTP10 40A 63 055	40	55	28	63	1,5	B63	●
63	BTP10 50A 63 080	50	80	42	63	4,3	B63	●
100	BTP10 50A 100 110	50	110	72	100	7,0	B100	●

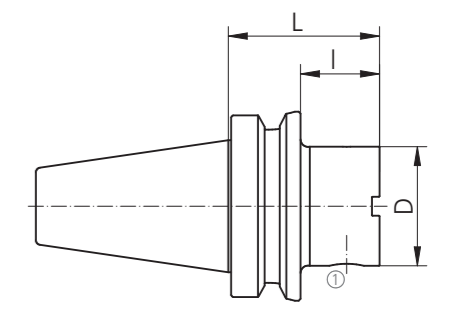

SPARE PARTS

Beta		Order Number
40		Z00 40 24
63		Z00 63 24
80		Z00 80 24
100		Z00 100 24

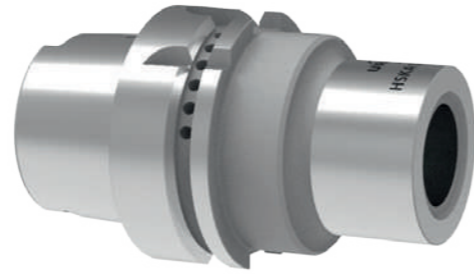

Conos de sistema
System adaptors

Conexión axial roscada
With axial threaded connection

DIN 69893-A

Alpha	Order Number	□	L	I	D	kg	MCC	Index
18,5	HSKA10 63 02*	63	57	15	18,5	1,0	18,5	●
24,5	HSKA10 63 07*	63	67	25	24,5	1,0	24,5	●
32	HSKA10 63 12*	63	67	25	32	1,1	32	●
42	HSKA10 63 17*	63	72	30	42	1,2	42	●
55	HSKA10 63 21*	63	82	56	55	1,4	55	●
42	HSKA10 100 17*	100	75	30	42	3,0	42	●
55	HSKA10 100 21*	100	85	40	55	3,3	55	●
72	HSKA10 100 26**	100	100	55	72	4,2	72	●
94	HSKA10 100 32**	100	125	96	94	6,0	94	●

* **Tubo refrigerante no incluido**
Coolant tube is not included

** **Tubo refrigerante incluido**
Coolant tube included

D = 72 mm con un chavetero
D = 94 mm con dos chaveteros
D = 72 mm with one driving keyway
D = 94 mm with two driving keyways

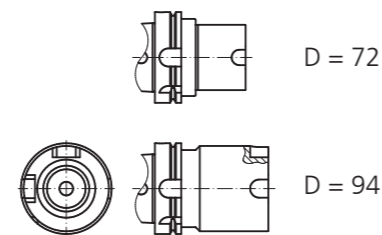
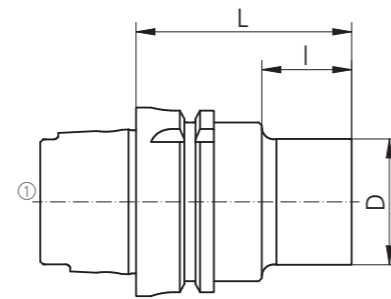

SPARE PARTS

□	①
63	H00 63 01
100	H00 100 01

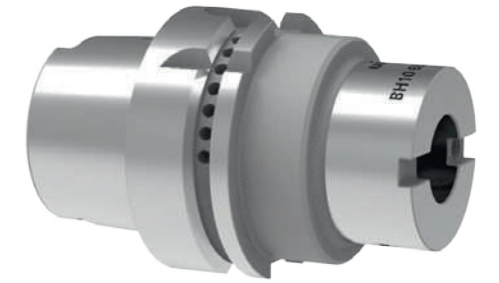

Conos de sistema
System adaptors

Sistema de bloqueo lateral
With side lock system

DIN 69893-A

Beta	Order Number	□	L	I	D	kg	MCC	Index
25	BH10 63A 25 055*	63	55	29	25	0,9	B25	●
32	BH10 63A 32 060*	63	60	34	32	1,0	B32	●
40	BH10 63A 40 065*	63	65	23	42	1,1	B40	●
50	BH10 63A 50 070*	63	70	28	50	1,5	B50	●
63	BH10 63A 63 080*	63	80	54	63	1,5	B63	●
32	BH10 100A 32 060*	100	60	31	32	2,3	B32	●
40	BH10 100A 40 080*	100	80	35	42	3,1	B40	●
50	BH10 100A 50 080*	100	80	35	50	3,2	B50	●
63	BH10 100A 63 080*	100	80	35	63	3,3	B63	●
80	BH10 100A 80 090*	100	90	45	80	4,0	B80	●
100	BH10 100A 100 100*	100	100	71	100	5,0	B100	●

* **Tubo refrigerante no incluido**
Coolant tube is not included

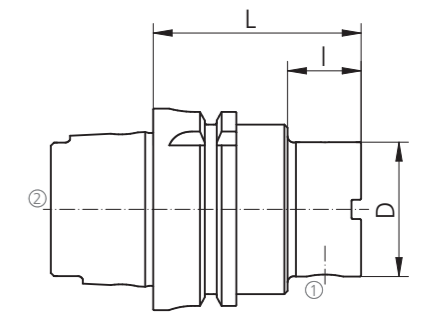

SPARE PARTS

Beta	①	□	②
25	Z00 25 24	63	H00 63 01
32	Z00 32 24	100	H00 100 01
40	Z00 40 24		
50	Z00 50 24		
63	Z00 63 24		
80	Z00 80 24		
100	Z00 100 24		

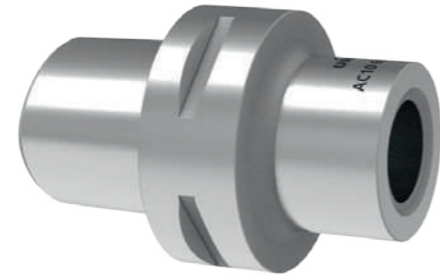

Conos de sistema
System adaptors

Conexión axial roscada
With axial threaded connection

ISO 26623 PSC

Alpha	Order Number	□	L	I	D	kg	MCC	Index
42	AC10 63 17 055	Size 6	55	30	42	1.0	42	●
55	AC10 63 21 060	Size 6	60	35	55	1.3	55	●

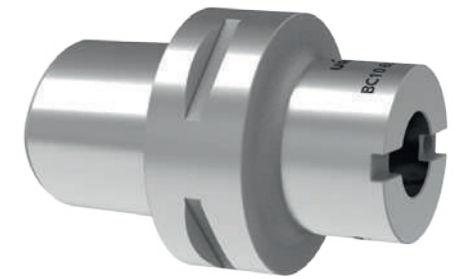
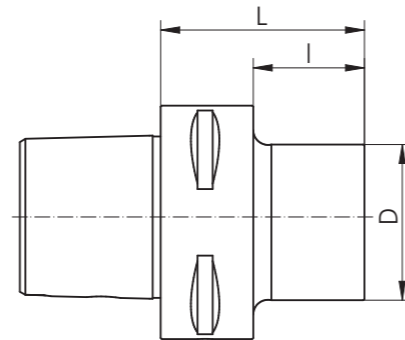

Conos de sistema
System adaptors

Sistema de bloqueo lateral
With side lock system

ISO 26623 PSC

Beta	Order Number	□	L	I	D	kg	MCC	Index
40	BC10 63 40 055	Size 6	55	30	42	1.0	B40	●
50	BC10 63 50 060	Size 6	60	35	50	1.2	B50	●
63	BC10 63 63 065	Size 6	65	-	63	1.5	B63	●

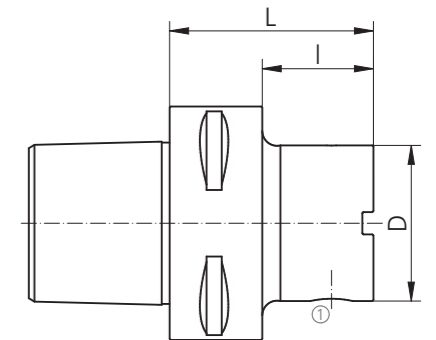

SPARE PARTS

Beta	①
40	Z00 40 24
50	Z00 50 24
63	Z00 63 24

URMA Systems
Adaptor Toolholders



Adaptadores porta fresas
Shell mill adaptors

Adaptadores porta fresas
Shell end mill adaptors

Beta	Order Number	L	I	D	d	kg	MCM	Index
63	B44 63 13 030	30	12	13	63	0,8	B63	○
	B44 63 16 030	30	17	16	63	0,8	B63	○
	B44 63 22 030	30	19	22	63	0,9	B63	○
	B44 63 27 030	30	21	27	63	1	B63	○
	B44 63 32 030	30	24	32	63	1,1	B63	○
	B44 63 40 030	30	27	40	63	1,3	B63	○

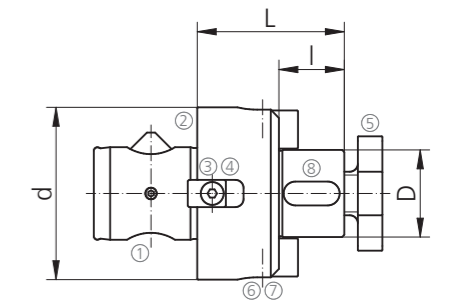

SPARE PARTS

D	①	②	③	④	⑤	⑥	⑦	⑧
	Z00 63 21	Z00 63 23	Z00 63 25	C00 22 05				
13					52 01 13	Z00 B44 16 01	C00 22 30	
16					52 01 16	Z00 B44 16 01	C00 22 30	F00 04 13
22					52 01 22	Z00 B44 22 01	C00 22 31	F00 04 14
27					52 01 27	Z00 B44 27 01	C00 22 05	F00 04 15
32					52 01 32	Z00 B44 32 01	C00 22 71	F00 04 16
40					52 01 40	Z00 B44 40 01	C00 22 71	F00 04 17



Adaptadores Weldon DIN 1835 B

Weldon adaptors DIN 1835 B

Adaptadores Weldon

Weldon adaptors

Beta	Order Number	L	I	D	d ₁	d ₂	kg	MCM	Index
40	B55 40 06 045	45	30	6	42	25	0,3	B40	○
40	B55 40 08 045	45	30	8	42	28	0,3	B40	○
40	B55 40 10 055	55	40	10	42	35	0,4	B40	○
40	B55 40 12 065	65	65	12	42	42	0,6	B40	○
63	B55 63 06 050	50	25	6	63	25	0,9	B63	○
63	B55 63 08 050	50	25	8	63	28	0,9	B63	○
63	B55 63 10 055	55	30	10	63	35	1	B63	○
63	B55 63 12 065	65	40	12	63	42	1,1	B63	○
63	B55 63 14 065	65	40	14	63	45	1,2	B63	○
63	B55 63 16 065	65	40	16	63	48	1,2	B63	○
63	B55 63 18 065	65	40	18	63	50	1,3	B63	○
63	B55 63 20 065	65	40	20	63	52	1,3	B63	○
63	B55 63 25 075	75	75	25	63	65	1,8	B63	○

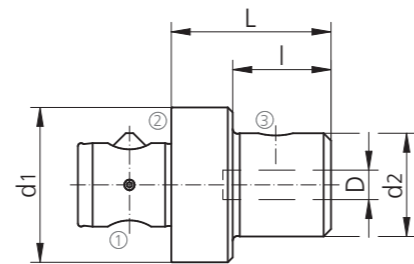

SPARE PARTS

Beta	D	①	②	③
40		Z00 40 21	Z00 40 23	
63		Z00 63 21	Z00 63 23	
	6			Z00 55 06
	8			Z00 55 08
	10			Z00 55 10
	12			Z00 55 12
	14			Z00 55 14
	16			Z00 55 16
	18			Z00 55 18
	20			Z00 55 20
	25			Z00 55 25

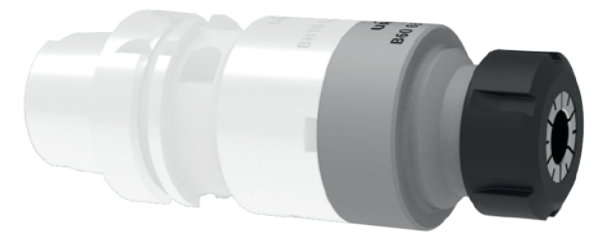

Adaptadores porta pinzas

Collet adaptors

Adaptadores porta pinzas

Collet adaptors

Beta	Order Number	L	D	d	kg	ER/ESX	MCM	Index
40	B60 40 25 065	65	42	42	0,4	25	B40	○
63	B60 63 32 065	65	63	50	1	32	B63	○

④ **No incluido en la entrega**
Not included in the delivery

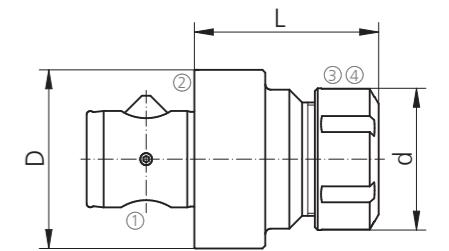

Set de pinzas

Collet sets

Order Number	L	D	d	ER/ESX	MCM	Index
62 25 00	34	1-15	26	25	ER25	○
62 32 00	40	2,0-20	33	32	ER32	○

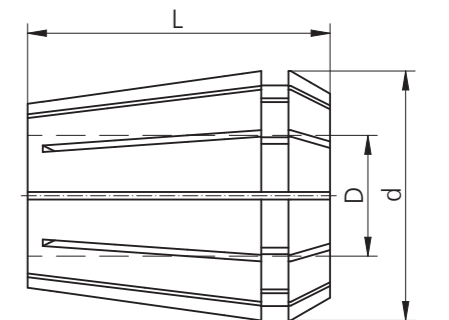

Pinzas unitarias

Single collets

Order Number	L	D	d	ER/ESX	MCM	Index
62 25 dd ¹⁾	34	1-17	26	25	ER25	○
62 32 dd ¹⁾	40	2,0-20	33	32	ER32	○

¹⁾ **indicar diámetro requerido**
indicate required diameter

SPARE PARTS

Beta	①	②	③	④
40	Z00 40 21	Z00 40 23	H00 05 05	00 05 05
63	Z00 63 21	Z00 63 23	H00 05 03	00 05 02

URMA Systems

Special Tools

Herramienta especial
Special tools

Disponibile bajo demanda
Available on request

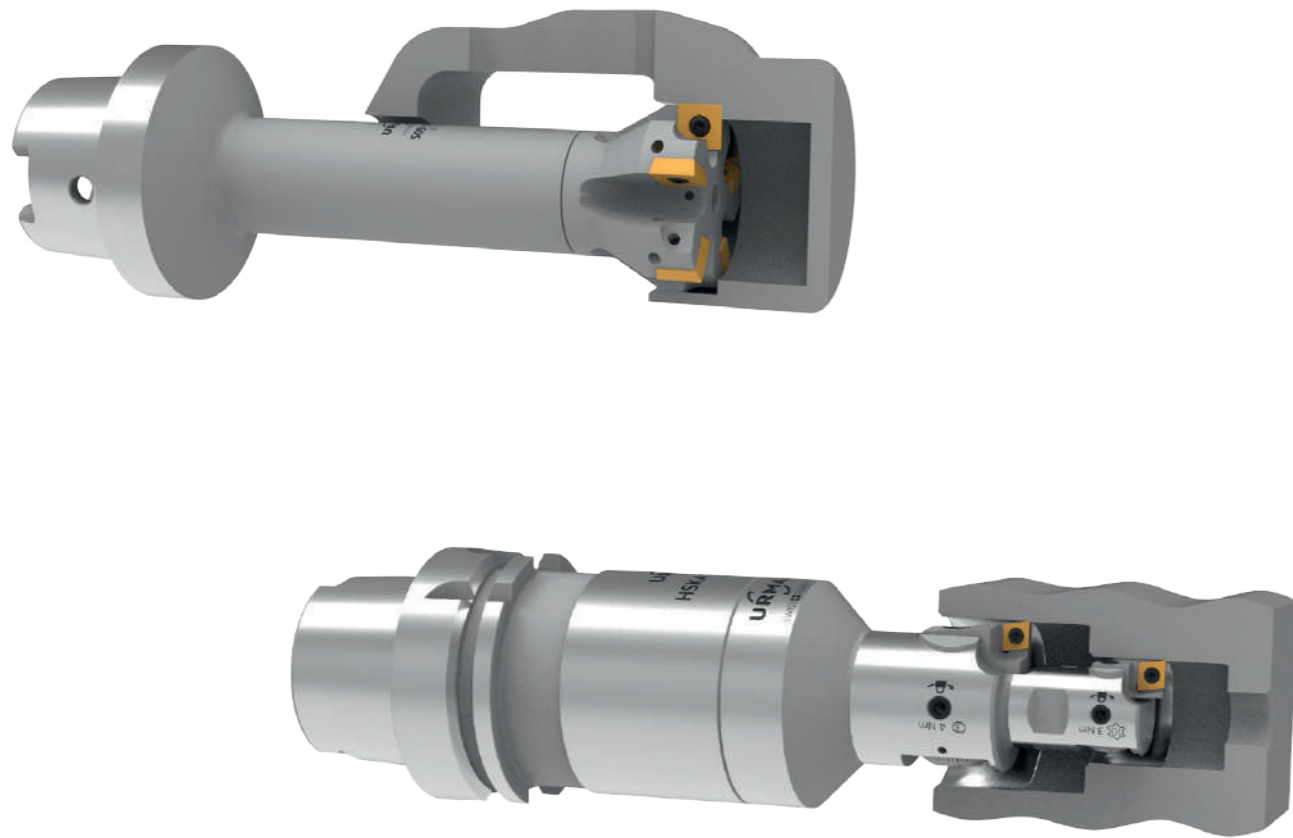

Herramienta especial
Special tools

Disponibile bajo demanda
Available on request

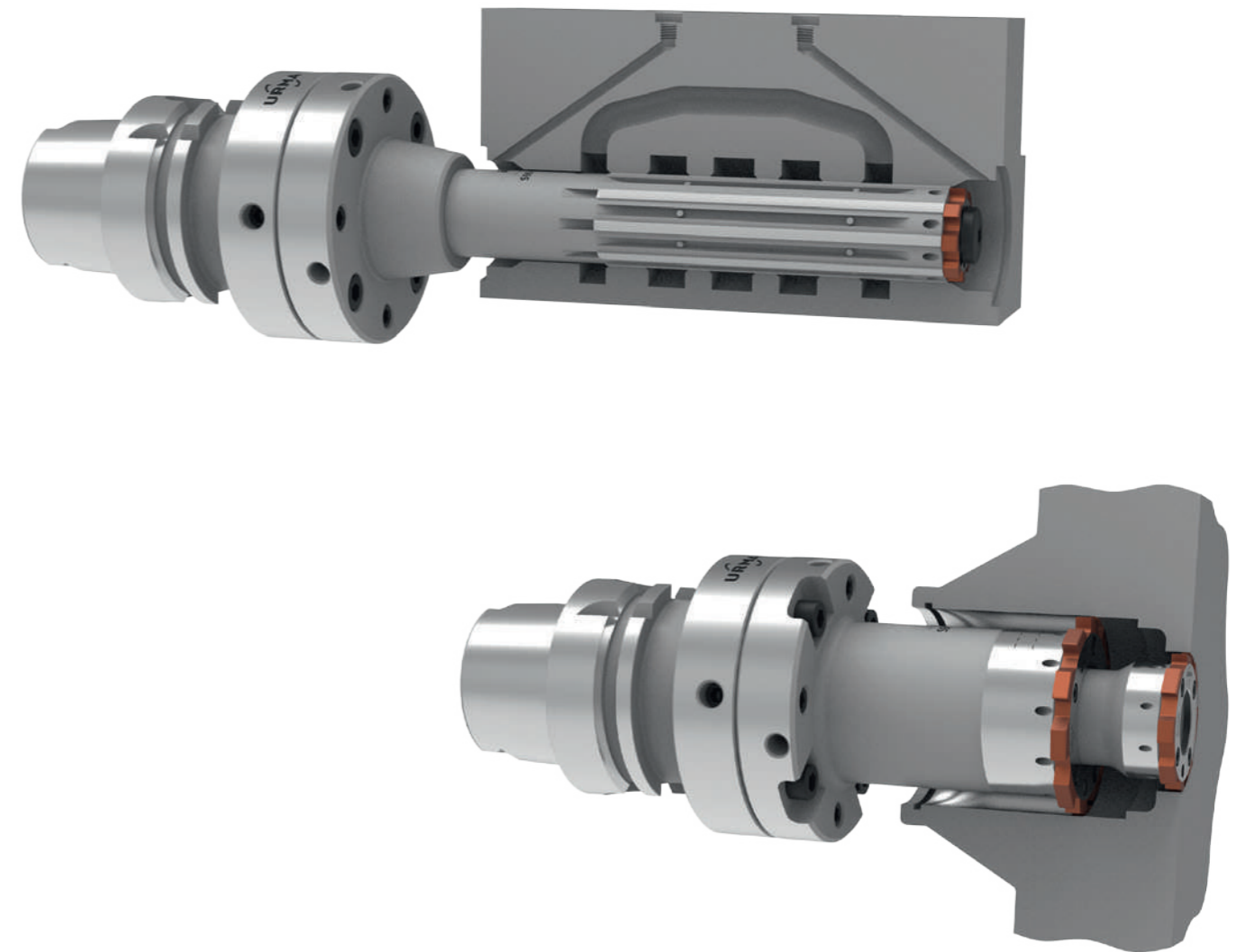

URMA Systems Machining Study

Estudio de mecanizado

Machining study

Remitente * Sender		Number
Compañía Company		Distribuidor URMA URMA Distributor
Adresse Address		Contacto Contact
		Departamento Department
Teléfono Telephone	Telefax Fax	Email E-Mail
Máquina Machine-tool		
Tipo de máquina Machine type		Potencia (kW) Drive power (kW)
Horizontal * <input type="checkbox"/>	Vertical * <input type="checkbox"/>	Herramienta rotativa * <input type="checkbox"/>
Agarre husillo * Spindle holder		Estabilidad Stability
Restricciones debidas a Restrictions due to		
Lubricante Lubricant		
Aceite * <input type="checkbox"/>	MMS * ¹⁾ <input type="checkbox"/> MLS ¹⁾	Emulsión * <input type="checkbox"/> Emulsion
Suministro de la refrigeración interior * Intern. coolant supply		Porcentaje de mezcla Ratio of mixture
		Presión del refrigerante (bar) * Coolant pressure (bar)
Pieza Workpiece		
Descripción Designation	Dibujo n° Drawing number	Material n° * Material number
Especificaciones * Specification	Tratamiento de la pieza * Treatment condition	Fuerza * Strength
Número de agujeros/año * Number of bores per year	N° piezas del lote Batch size	
Requisitos de la pieza Machining requirements		
Diámetro del agujero * Bore ø	Longitud del agujero * Bore length	Diámetro pre-mecanizado * Pre-machined ø
Tolerancia * Tolerance	Longitud herramienta (xs) Gage length (xs)	Metodo de pre-mecanizado * Method of pre-machining
Requisitos adicionales de tolerancia Additional tolerance requirements	Agujero ciego * <input type="checkbox"/>	Tiempo objetivo Target time
Calidad superficie (µm) * Surface quality (µm)	Corte interrumpido * <input type="checkbox"/>	Cantidad objetivo Target quantity
R _a <input type="checkbox"/> R _z <input type="checkbox"/> R _t <input type="checkbox"/>	Tiempo de ciclo <input type="checkbox"/> Cycle time	
Fecha * Date	Visto bueno * Visa	Adjunto: Dibujo de la aplicación * Attachement: Your application sketch

* Campos obligatorios
Mandatory fields

¹⁾ Micro lubricación
Minimal lubrication system (mist coolant)

Fax +41 62 889 20 28
customerservice@urma.ch

URMA Systems Manuals

Montaje del sistema Alpha-Modul

Assembly of systems Alpha-Modul

- | | |
|--|--|
| 1. Aflojar el tornillo de bloqueo con llave allen pequeña (en sentido horario) | 1. Loosen locking screw with small hexagonal key (turn counter clock wise) |
| 2. Atar el tornillo roscado con la llave allen larga (en sentido horario) hacia abajo | 2. Screw threaded plug with large hexagonal key (clockwise) down to the bottom |
| 3. Roscar el doble cabezal y el adaptador juntos hasta que la ranura y la chaveta se alineen | 3. Screw double cutter head and adaptor together until the slot and key align |
| 4. Atar el tornillo roscado dentro del adaptador con la llave allen larga sentido horario. Apretar el tornillo de fijación con la llave hexagonal en sentido horario | 4. Screw threaded plug into the adaptor with the large hexagonal key by turning counter clock wise. Tighten the locking screw with the small hexagonal key by turning clock wise |

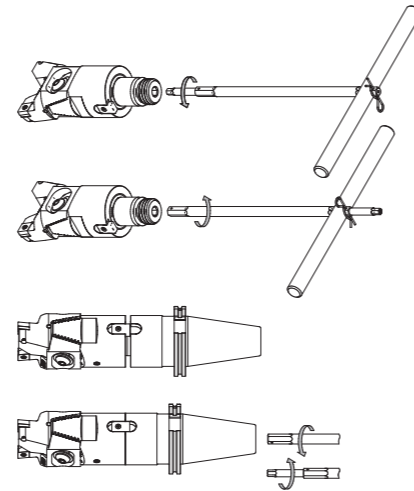

Montaje de componentes Beta-Modul

Assembly of Beta-Modul components

- | | |
|--|--|
| 1. Antes de montar, chequear que el perno flotante esta correctamente montado (la muesca debe apuntar hacia el tornillo) | 1. Before assembling, check that the floating bolt has been correctly mounted (indentation must point towards the screw) |
| 2. Si utilizamos adaptadores estandar, debemos girar la llave 180° (valido desde tamaño 40) | 2. If standard adaptors are being used, the keyway must be turned through 180° (valid from system size 40) |

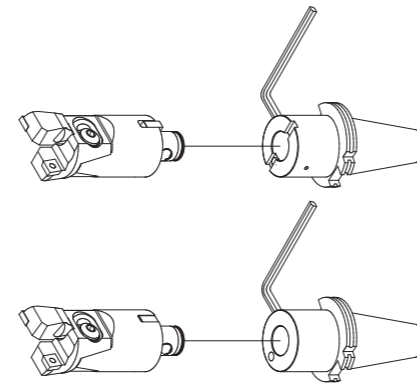

Orientación del filo de corte en cabezales de acabado

Cutting edge orientation of fine boring heads

Ø 0.2 - 153 mm

MicroMax, VersaMax - Type 25/A25

- | | |
|---|---|
| 1. Aflojar el tornillo de bloqueo con una llave inglesa | 1. Loosening the locking screw, screw the threaded plug in completely with the spanner |
| 2. Atar el tornillo en la cabeza de acabado hasta que ambas caras y el adaptador este en contacto - definir el ángulo de corrección (Alpha) | 2. Screw in the boring head until both faces boring head and adaptor are in contact - define the correction angle (Alpha) |
| 3. Soltar el tornillo roscado con la llave inglesa 1,5 veces hacia el ángulo de corrección (Alpha). Apretar el tornillo de bloqueo. | 3. Unscrew the threaded plug with the spanner by about 1,5 times the correction angle (Alpha). Re-tighten the locking screw |
| 4. El filo de corte ahora esta orientado en la posición de parada del adaptador | 4. The cutting edge is now orientated on the stop-position of the adaptor |

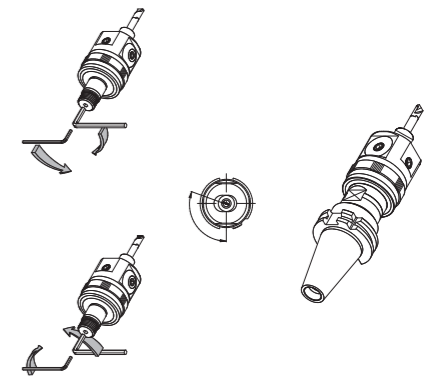

Equilibrado del cabezal de acabado A25

Balancing the fine boring head

Ø 0.2 - 40 mm

MicroMax

- | | |
|--|---|
| 1. Soltar el tornillo de bloqueo A en el anillo equilibrado | 1. Loosen the locking screw A on the balance ring |
| 2. Alinear las dos escalas para fijar el diámetro del agujero. La escala B corresponde a las barras de acero, y la escala C a las de metal duro. | 2. Align the two scales to set the bore diameter. Scale B corresponds with steel boring bars, scale C with carbide boring bars. |
| 3. Apretar el tornillo de bloqueo | 3. Re-tighten the locking screw |
| 4. El cabezal de acabado ahora esta automaticamente equilibrado para el diámetro a mandrinar requerido | 4. The boring head is now automatically balanced for the required boring diameter |

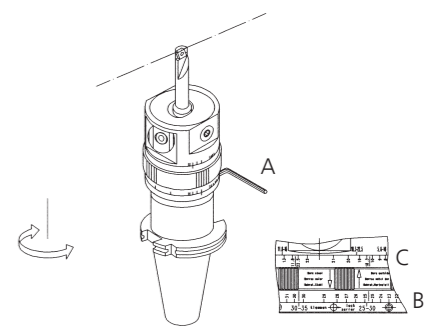

Equilibrado del cabezal de acabado A25

Balancing the fine boring head

VersaMax - Type A25

Ejemplo \varnothing 53 mm

Para equilibrar el A25, simplemente posicionar los anillos graduados al valor del diámetro requerido y fijar

Example \varnothing 53 mm

To balance the A25, simply position the graduated rings to the required diameter value and lock

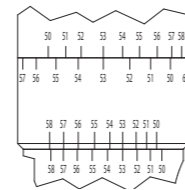

Ajuste de cabezales de acabado

Pre-setting fine boring heads

MicroMax, VersaMax - Type 25/A25

- | | |
|---|--|
| 1. Soltar el tornillo de fijación A | 1. Loosen locking screw A |
| 2. Fijar el diámetro a mandrinar en el micrometro, tornillo B | 2. Set the boring diameter at the micrometer screw B |
| 3. Apretar nuevamente el tornillo de bloqueo | 3. Re-tighten the locking screw |

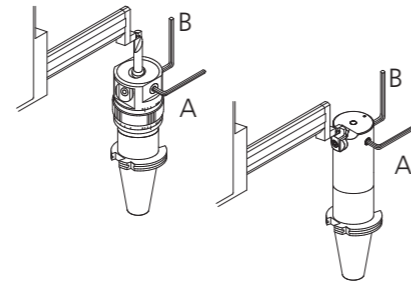

\varnothing 20 - 67 mm

\varnothing 0.2 - 153 mm

Montaje del sistema IntraMax

Assembly of system IntraMax

IntraMax

- | | |
|---|---|
| 1. Montar el adaptador del diámetro (si se requiere), en el adaptador o adaptador intermedio con cuatro tornillos A | 1. Mount the diameter adaptor (if needed) onto the adaptor or intermediate adaptor with four screws A |
| 2. Montar los porta útiles de acabado o desbaste con tornillos B cada uno (normalmente, se montan dos cabezas a la vez) | 2. Mount the roughing or finishing insert holders with two screws B each (normally, two heads are mounted at the same time) |
| 3. Alinear los porta placas utilizando las referencias de la cabeza y del adaptador | 3. Align the insert holders using the coarse graduations on the head and the adaptor |
| 4. Para mecanizado exterior, debemos montar el adaptador intermedio, C | 4. For external machining, the intermediate adaptor must be mounted, C |
| 5. Después, montar las placas de acabado o desbaste con dos tornillos, D | 5. Then mount the roughing or finishing insert holders with two screws C |

\varnothing 49 - 297 mm

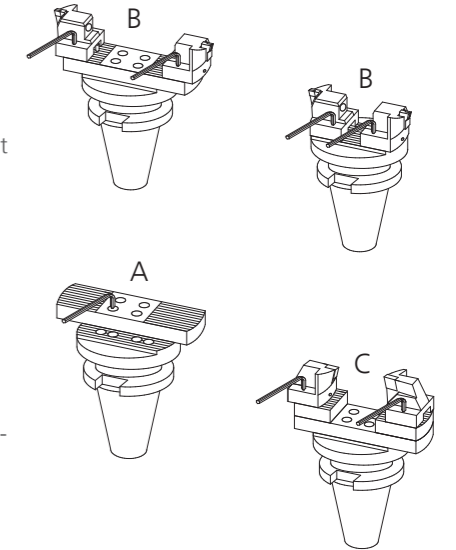

Montaje del sistema

Assembly of system

MegaMax

- | | |
|---|--|
| <ol style="list-style-type: none"> 1. El extensor de diámetro esta atado al adaptador intermedio con cuatro tornillos, A 2. Los porta utilies de desbaste y los cabezales de acabado, deslizan lateralmente hacia la línea dentada y después rota, B. Con el extensor de diámetro 150-250 mm también es necesario soltar totalmente el tornillo amarrando los tornillos C y fijando los después de montar las cabezas (Observar el agujero roscado en el perno de amarre D). 3. Alinear los porta placas utilizando las referencias de la cabeza y del adaptador | <ol style="list-style-type: none"> 1. The diameter extender is fastened to the intermediate adaptor with four bolts A 2. Roughing insert holders and fine boring heads are slid laterally across the line of the serration and then rotated B. With diameter extenders \varnothing 150-250 mm it is also necessary to fully unscrew the clamping screws C and refit them after mounting the heads (note taper bore on clamping bolt D). 3. Align the insert holders using the coarse graduations on the head and the adaptor |
|---|--|

\varnothing 150 - 805 mm

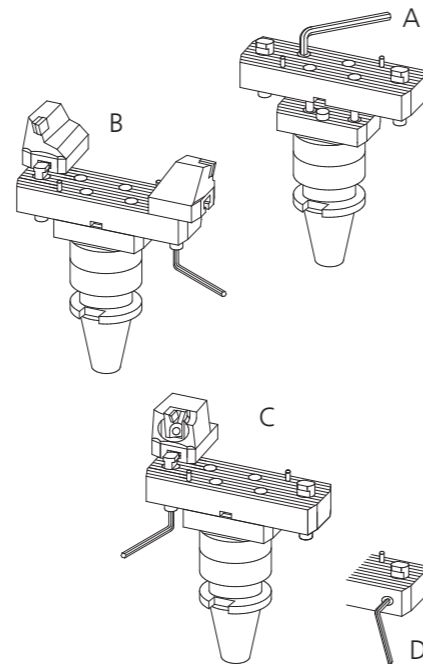

Preparación de las herramientas

Pre-setting the system

IntraMax, MegaMax, SuperMegaMax

- | | |
|---|---|
| <ol style="list-style-type: none"> 1. Fijar el diámetro a mandrinar en el pre-setter utilizando la cara A o ajustando el tornillo D respectivamente 2. Apretar la cara a fijar bloqueando el dispositivo E 3. Si debes usar dos cabezales de acabado simultáneamente, suelta la placa de acabado utilizando la llave C, fija la cuchilla con la llave B y fija nuevamente con la llave C | <ol style="list-style-type: none"> 1. Set the boring diameter to the pre-set position using setting dial A or adjusting screw D respectively 2. Tighten the setting dial locking device E 3. If two fine boring heads are to be used simultaneously, loosen the fine boring insert using key C, set the blade with key B, and reclamp with the key C |
|---|---|

\varnothing 49 - 2'400 mm

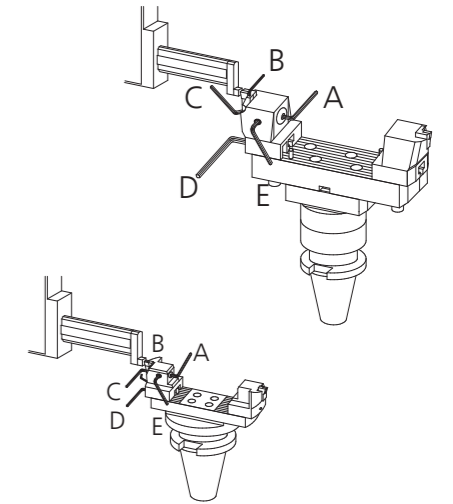

Colocación del diámetro en un cabeza de doble corte

Setting the bore diameter on a double cutter

\varnothing 19.5 - 153 mm

VersaMax - Type 14

- | | |
|---|--|
| <ol style="list-style-type: none"> 1. Apretar suavemente el tornillo de amarre A (debe fijarse la arandela levantada) 2. Fijar la placa al diámetro exacto y después ajustar el tornillo B 3. Apretar firmemente el tornillo de amarre A | <ol style="list-style-type: none"> 1. Gently tighten clamping screws A (spring washer must be fitted) 2. Set the cutter to the exact diameter with the adjusting screw B 3. Firmly tighten clamping screw A |
|---|--|

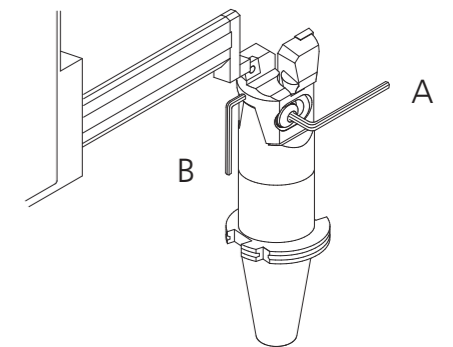

URMA Systems
WinTool

WinTool

Gestión e-tool con catalogo URMA E-Tool management with URMA catalogue

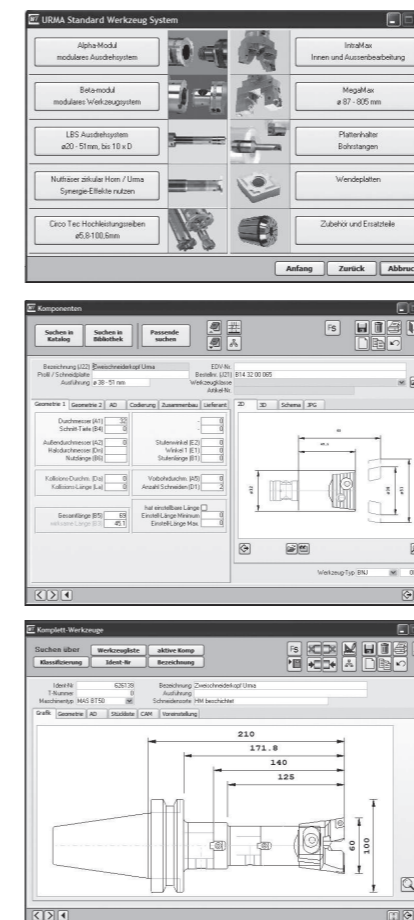

El sistema de gestión estándar, con el catalogo de URMA integrado, ofrece los componentes de la herramientas y las herramientas montadas.

El último programa y catalogos de WinTool está disponibles y se pueden descargar desde www.wintool.com

Tool Sheet Urma

600035 **Zweischneiderkopf Urma** Machine Typ - no attachment -

Diameter	60
Cutting length	0
Radius	0
Main Arc	0
Length	210
Width	0
Collision Lgt. (L3)	145.6
Collision Dia.	100
Cutting Width	0
Side Angle	0
Weight	5.4
Price	0

Recorded 05.02.2016 Modified 05.02.2016

Product Code / Sort	Description / Item No.	
1 BT10 50A 50 070 a 50x70 mm Beta-modul	Aufnahme URMA BT -A	
1 B12 50 40 050 a 50/40x50 mm Beta-modul	Reduktion URMA	
1 B14 40 00 090 a 50 - 67 mm	Zweischneiderkopf Urma	
2 W16 08 09 CC... 09T3... a 50 - 67 mm	Zweischneider Plattenhalter 90	

Cold work tool steel
low alloyed up to 1000 N/mm²

ap	ae	D	z	Vc	fz	S	F	P	T (min)
3	30	60	2	220	0.2	1167	466.8	0	0

The standard tool management system with integrated URMA catalogue delivers tool components and assembled tools.

The latest WinTool software and catalog versions are available in various languages and downloadable for free from: www.wintool.com



URMA AG WERKZEUGFABRIK

Obermatt 3
CH-5102 Ruppertswil
Switzerland
T +41 62 889 20 20
F +41 62 889 20 28
info@urma.ch
www.urma.ch

Subsidiaries

URMA GmbH
Eisenbahnstraße 37
DE-77815 Bühl
+49 7223 911 170
info@urma-gmbh.de

URMA Trading (Shanghai) Co. Ltd.
Room 511, Hua Nan Mansion
1988 Dongfang Road
Pudong New District
CN-200125 Shanghai
+86 (21) 6109 6216
info@urmachina.com

Iraupen URMA
Poligono Belartza
ES-20018 Donostia-San Sebastian
Spain
+34 943 667 036
info@iraupen.es

License Manufacturer

Command Tooling Systems, LLC
13931 Sunfish Lake Blvd.
Ramsey MN, 55303 USA
+1 800 328 2197
support@commandtool.com

Paul Horn GmbH
Unter dem Holz 33-35
DE-72072 Tübingen
+49 (0) 7071 7004 0
info@phorn.de

Sumitomo Electric Ind., Ltd.
1-1-1, Koyakita,
Itami-shi, Hyogo 664-0016
Japan
+81 72 772 4535
info@sumitomotool.com